

Code of Practice 613

Issue 9 September 2024

Connection and Operation of Mobile Generators at Low Voltage



Amendment Summary

ISSUE NO. DATE	DESCRIPTION
Issue 8 April 2021	<p>Restructure and reformatting of Model Code of Practice. This 2021 issue constitutes a complete revision and re-issue of Model Code of Practice in its entirety. More detail has been added to appendix E3 LV Generator Synchronised Connection to/from Energised Network.</p> <p>Prepared by: David M Talbot Approved by: Policy Approval Panel and signed on its behalf by Steve Cox, Engineering and Technical Director</p>
Issue 9 September 2024	<p>New section 8.3.1 added for generator exhaust fumes.</p> <p>Prepared by: David M Talbot Approved by: Policy Approval Panel and signed on its behalf by Paul Turner, PAP Chairperson</p>

Contents

1	Introduction	5
2	Scope	5
3	Definitions	6
4	Safety	6
	4.1 Risk Assessment	6
5	Training	7
	5.1 General	7
	5.2 Transportation of Fuel	8
6	Introduction to LV Mobile Generators	8
	6.1 Typical Mobile Generator	8
	6.2 Typical Control Panel Layout	9
	6.3 Running Time	9
	6.4 Generator Rating	10
	6.5 Connecting Leads	10
	6.6 Cable Connectors	10
7	Selection of LV Mobile Generators	11
	7.1 Considerations Prior to Selecting and Requesting a Mobile Generator	11
	7.2 Generator Size	12
	7.3 Connection Points	12
	7.4 Supply Standards	13
	7.5 Requesting a Generator (Planned/Fault)	13
8	Deployment of LV Mobile Generators	14
	8.1 General	14
	8.2 Pre-use Checks	14
	8.3 Siting the Generator	15
	8.4 Where Generator is Electrically Adjacent to Work	17
	8.5 Inline Fusing / Circuit Breaker Module	18
	8.6 Selecting/Preparing a Suitable Earth	18
	8.7 Pulling Out, Inspecting and Protecting Cables	19
	8.8 Connecting the LV Cables to the Generator	19
	8.9 Connecting LV Cables from the Generator to the Electrical Distribution System Apparatus	20
	8.10 Operating/Monitoring the Generator	23

8.11	Disconnecting the Generator	23
8.12	Return of Generator, Post-Use Checks and Maintenance	24
9	Documents Referenced	24
10	Keywords	25
	Appendix A – Request for Mobile Generators and Record of Use	26
	Appendix B – Generator Security Risk Assessment	27
	Appendix C – Cable Colours	30
	Appendix D – Typical Procedures for Connecting Small Generators to Single-Phase Consumers	31
D1	Connection of Suitcase Generator	31
	Fig. D1 Connection of Suitcase Generator to Single-Phase Customer	31
D2	Connection of Small Generator (Up to 10kVA)	33
	Fig. D2 Connection of Small Generator to Single-Phase Customer	33
	D2.1 Procedure	33
	Appendix E – Typical Procedures & Equipment for Supply Restoration Using Generators	35
E1	LV Generator Connection to Low Voltage Cables	35
	E1.1 Initial Assessment Points for Consideration	35
	E1.2 Location of Excavation shall take into Account:	35
	E1.3 Preparation of Cable for Generator Connection	35
	E1.4 Connecting Generator Leads	36
	E1.5 Operation of Generator	36
	E1.6 Disconnection of Generator	36
	E1.7 LV Shrouding Specification for Outdoor Plant Left Unattended	36
E2	LV Generator Connection to/from any De-energised Network	37
	E2.1 Procedure	37
E3	LV Generator Synchronised Connection to/from Energised Network	38
	E3.1 Procedure	38

All Rights Reserved

The copyright of this document, which contains information of a proprietary nature, is vested in Electricity North West Limited. The contents of this document may not be used for purposes other than that for which it has been supplied and may not be reproduced, either wholly or in part, in any way whatsoever. It may not be used by, or its contents divulged to, any other person whatsoever without the prior written permission of Electricity North West Limited.

1 Introduction

This Code of Practice covers the selection and deployment of mobile generators used on the Low Voltage Electricity Distribution Network (LV Network) owned by Electricity North West Limited (Electricity North West), as Distribution Licensee.

For information on supply restoration and the decision making process about whether or not to use mobile generators, refer to CP618 and EPD613.

Only Personal Protective Equipment (PPE), tools, other equipment and consumables that are approved for use by Electricity North West shall be used. These items include generators and link handles.

2 Scope

This Code of Practice covers the use of all mobile generators on the LV Network. It does not cover associated tasks such as excavating joint bays or signing, lighting and guarding of road works. Associated tasks that are referred to within this Code Practice, but are not covered here, are detailed in the following documents:

- LV supply restoration strategy is covered in CP618.
- Work carried out under the New Roads and Street Works Act shall comply with CP102.
- Signing, lighting, guarding and diversions in line with the New Roads and Street Works Act are covered in the New Red Book: "Safety at Street Works and Road Works – A Code of Practice".
- Excavation and jointing are covered in CP411 Pt1N.
- Further background detail on the requirements of mobile generators, etc, is included in ENA ER G84 (*Recommendations for connection of mobile generating sets in public distribution network*).

All work shall be carried out under the Distribution Safety Rules and in accordance with other relevant CP600-series Operational Codes of Practice.

3 Definitions

Generally, as per ENA ER G84, but with the following differences:

HV AP	High Voltage Authorised Person
Mobile Generator	Generating Set as defined in ENA ER G84

4 Safety

4.1 Risk Assessment

4.1.1 Point of Work Risk Assessment (POWRA)/Generator Risk Assessment

All generators that are deployed on planned or reactive works will ideally have generator risk assessment carried out in addition to a POWRA. In the case that only a POWRA has been carried out, the site lead or person conducting the risk assessment must ensure that the guidance in CP613 is adhered to. They SHALL ensure the appropriate actions have been taken to mitigate risks on site highlighted and recorded in the POWRA. Samples of both can be seen within [Appendix B](#) of this document.

4.1.2 Dynamic Point-of-Work Risk Assessment

Dynamic point-of-work risk assessments shall be carried out as the work progresses. Refer to [Appendix B](#) for guidance on basic points to consider throughout this code of practice.

If at any stage the work cannot be continued safely, it shall be postponed until a safe alternative can be implemented.

4.1.3 Hazards

The procedures covered by this Code of Practice have the following specific hazards associated with them:

- Electrical hazards (electrocution, arcing burns).
- Other thermal hazards (hot equipment, scalding fluid, flammable fluid).
- Mechanical hazards (crushing, shearing, etc).
- Noise.
- Vibration.
- Fumes / products of combustion
- CO

This is potentially a HIGH risk task (i.e.) risk of death or serious injury.

4.1.4 Control Measures

This Code of Practice incorporates the risk control measures that shall be applied when carrying out the tasks. In addition, the following Personal Protective Equipment (PPE) shall be used to mitigate the hazards:

- Eye protection.
- Safety footwear.
- Gloves.
- Hi-visibility clothing.
- Arc-resistant coverall.
- Ear protection.

Before and throughout any Live switching or making/breaking Live connections, the following PPE shall be worn:

- Arc-resistant coverall.
- Arc-resistant hood.
- Insulated gloves.

None of the above PPE shall be removed until the Live operations have been successfully completed.

General additional measures include:

- Minimising contact with vibrating plant and equipment.
- Keeping flammable fluids away from potential sources of ignition. If the risk control measures detailed in this Code of Practice are implemented the risks will be LOW.

Risk assessments for the tasks listed in the Scope above (tasks associated with this Code of Practice, but not included) are included in the relevant codes of practice.

5 Training

5.1 General

All persons required to take charge of connecting and/or operating mobile generators shall have successfully completed the City and Guilds course 232 (Electrical and Electronic Craft Studies) or equivalent.

All persons shall hold the appropriate Authorisation/Competency code, or the appropriate Generator Code. Basic Generator Training course EO338 is available prior to obtaining a Generator Code followed by EO1026 refresher every three years. Generator Code and EO338 training is not required for HV AP and above, providing sufficient training and knowledge has been acquired.

Before any person is authorised (competent) in writing, to connect and operate mobile generators, that person shall have successfully:

- Completed the H100 course (Basic Electrical Safety (including substations)).
- Completed a hands-on mobile generator familiarisation course (EO338), unless HV AP or above with sufficient training and knowledge (as stated above).
- Received sufficient on-job training. (Details of training requirements are included in CP614.)

All connection and operational work associated with the use of mobile generators shall be done in strict compliance with Electricity North West Distribution Safety Rules, The Electricity at Work Regulations (1989), The Electricity Safety, Quality and Continuity Regulations (2002) and this Code of Practice (CP613). Consequently, anyone authorised to connect and operate mobile generators must be conversant with the relevant sections of these documents.

5.2 Transportation of Fuel

The transportation of fuel via a separate bowser requires an Accord Dangereux Routier (ADR) license if the quantity is over 1000 litres.

6 Introduction to LV Mobile Generators

6.1 Typical Mobile Generator



The photograph above shows a typical mobile generator. The example shown is a trailer-mounted 100kVA generator. Mobile generators can also be truck or skid mounted. The generators are enclosed in a sound-attenuated container with louvres next to the radiator. Cooling air is drawn across the diesel engine and through the radiator, venting to the atmosphere through the louvres, hence the greatest noise is adjacent to

the louvres. Where practical the generator shall be sited so that the louvres face away from the direction most sensitive to noise.

6.2 Typical Control Panel Layout



The photograph above shows the control panel of the above generator.

NOTE: that whilst the generator is running, all doors shall be closed and locked to minimise noise pollution and prevent unauthorised access.

6.3 Running Time

Consideration must be given to:

- The amount of fuel that may be required, depending on load and the length of time the generator will be required.
- The practicalities of re-fuelling the generator when selecting its location on site.

The current specification for fuel tank capacity allows:

- Approximately 18 hours full load operation for truck-mounted sets.
- Approximately 10 hours full load operation for trailer-mounted sets.
- Refuelling whilst on load.

6.4 Generator Rating

The convention for rating of mobile generators is expressed in kVA or kW at 0.8 power factor. This means that a 100kVA mobile generator can supply a maximum power of 80kW. If switching on to a Dead connected load, the normal maximum power output that the generator can generate without stalling is about 60% of the full load rating, ie approximately 50kW.

6.5 Connecting Leads

Connecting leads are generally orange or black. However, in order to discriminate between phases, neutral and earth, every cable shall be permanently colour-coded at both ends with the appropriate colour (phase colour, neutral or earth) in accordance with [Appendix C](#).

All LV phase and neutral connecting cables supplied with the generators shall:

- Comply with BS 5467.
- Be matched to the rating of the generator.
- Be multi-stranded flexible copper, double cover insulation and marked/embossed 1000V cable.
- Be fitted with colour co-ordinated connectors to the UK standard so that the phase, neutral and earth cables are readily identifiable.
- Have flame retardant properties.
- Be waterproof, scuff and tear resistant.
- Be oil and chemical resistant.

At every stage, connecting leads shall be protected as reasonably practicable from damage.

All LV earth connecting cables must be multi-stranded copper, flexible single-insulated to 600/1000V cable to BS 5467 where appropriate and have the same cross sectional area as the phase conductors up to 70mm².

6.6 Cable Connectors

Colour co-ordinated cable connectors, to the UK standard of a plug and twist design (Litton Veam), which are waterproof to IP67, must be used on all generators. The rating of cable connectors shall be matched to the cable and the associated generator. Refer to [Appendix C](#) for cable colours.

Caps (where provided) shall be replaced on all panel and cable connectors, when not in service, to keep the contact surfaces clean, therefore ensuring good electrical contact when in service.

These connectors are not designed or rated to be load making or breaking and shall only be made and broken with the cable Dead.

7 Selection of LV Mobile Generators

7.1 Considerations Prior to Selecting and Requesting a Mobile Generator

In the case of a neutral fault, the exact location of the neutral fault must be known and isolated, and the supplies must be checked and confirmed safe for re-energisation before a generator can be connected.

Where the earthing/protection requirements specified in [Section 8.6](#) cannot be met, a generator shall NOT be used.

When considering using a mobile generator an assessment shall be made to determine:

- The size of generator required.
- The practical availability of a suitable connection point.
- The ability to protect the connection cables.
- The accessibility to this location bearing in mind:

Any road weight restrictions, particularly private access ways which may not have been constructed to support heavy vehicles.

Width and state of access roads and heights of bridges, etc.

Environmental aspects shall also be considered such as:

- Public safety and additional security requirements.
- Noise. (If noise could be an issue, consider the use of acoustic panelling or a low-noise generator.)
- Exhaust. (The engine will produce carbon dioxide and carbon monoxide, therefore, care shall be taken when operating the generator near excavations, other confined spaces or building vents, etc.)
- Unacceptable obstruction to other road users etc. (Full compliance with the New Roads and Street Works Act 1991 is a statutory requirement – refer to CP102.)
- Risk of flooding.
- Keeping fluids (petrol, diesel, etc) away from water courses. (Spill kits shall be available for immediate use.)

From time-to-time circumstances may arise where an operator is unable to understand alarm signals, etc, or requires assistance but is unable to leave site (for example unable to close substation door). In situations where a single operator would be unable to summon any assistance without leaving site (for example no mobile phone signal), there must be more than one person on site.

7.2 Generator Size

An assessment shall be made of the size of the load that is to be supplied by the mobile generator(s) and efforts shall be made to determine whether any large motors or welding sets are included in the load. The use of maximum demand indicators, clip on ammeters (if they can be applied safely) and/or other proprietary recording ammeters may be helpful in assessing the load to be supplied.

For planned shutdown type work the use of a load data logger (squirrel) may be used for a period of time to more accurately determine the demand that is to be supplied.

Small portable generators up to 10kVA Inverter type, used for single-phase domestic applications, will normally be connected at the service position using one of methods detailed in [Appendix D](#). Typical examples of such situations would be:

- Houses.
- At marinas.
- At caravan sites.

Where full information is not available the following guide may be used:

TRANSFORMER SIZE (KVA)	SUGGESTED GENERATOR (KVA)
1000	500 – 1500
750	500 – 1500
500	300 - 625
300/315	250 - 350
200	150 - 250
100 or less	100 - 150

Be aware that this will not be correct for all situations. On purely domestic networks in mid-summer during the day a further reduction of 50% may be possible. On heavily industrialised networks in mid-winter full transformer capacity or more may be required.

If the chosen generator is too small, it will stall when too much load is added and could sustain damage as a result. Consider a larger generator if consumers have been off for some time (cold load pick up).

7.3 Connection Points

Having determined the anticipated load it is necessary to assess where it is practical to make a connection to the distribution network or to a customer's equipment of adequate rating to cater for the load. To obtain the greatest benefit, it is preferred, where possible, to connect and synchronise the mobile generator to the load and subsequently disconnect it without interrupting the supply.

NOTE: that if connecting live in a substation (as below), the leads will not be effectively protected (only by HV) until feeding from the generator.

Typical connection points:

- The preferred option is:

Remove fuses on one way in a distribution substation and replace with a generator fuse (fuse handle with Litton Veam connector) to which a generator lead can be attached. In this instance it may be necessary to interrupt the supply to those customers connected to that way in the substation, if it is not possible to backfeed.

Where practicable, leave these fuse carriers in place for future use after the generator has been disconnected.

- Clamp to bare busbars in distribution substation.
- Connect to busbar terminals on a spare way in a distribution substation.
- Backfeed one way into substation, remove fuses on that way and connect to busbar terminals.
- Clamp using LV Live line connectors only (not HV type) to bare wire LV overhead line.
- Clamp to working earthing points on ABC overhead lines. It may be necessary to fit earthing points to the ABC line in advance, but this work can be done Live using the appropriate techniques.
- Direct connection to an underground cable using approved, rated connectors.
- Direct connection to a customer's termination (Mod panel/cut-out/Bemco).

7.4 Supply Standards

The Electricity Safety, Quality and Continuity Regulations 2002 specify the electricity supply standards. These are:

- Voltage must be 230V +10% to -6% (ie within the range 253 to 216V).
- Frequency must be 50Hz +/- 1% (ie within the range 50.5 to 49.5Hz).
- Wave form must be sinusoidal.

Generators which cannot meet these requirements shall not be used on the Network.

The generator voltage and frequency shall be checked on-site to ensure these requirements are being met.

7.5 Requesting a Generator (Planned/Fault)

On completion of the above sub-sections of Section [7](#), Part 1 of the 'Request for Mobile Generator and Record of Use' form ([Appendix A](#)) shall be completed, either:

- In paper copy form and passed to the person responsible for co-ordinating the allocation of generators, or
- Directly on the appropriate TMS or NMS screen's.

8 Deployment of LV Mobile Generators

8.1 General

There are many different scenarios in which a generator will be deployed, therefore example procedures covering typical scenarios are included in Appendices [D](#) and [E](#).

The background detail for carrying out the procedures outlined in Appendices [D](#) and [E](#) is included in Sections 8.2 onwards.

8.2 Pre-use Checks

8.2.1 Mobile Generator

Whether the generator is owned by Electricity North West or a third party, the following fit-for-purpose checks shall be carried out by the user prior to driving or towing the generator to site:

- Ensure that there is an up-to-date test certificate to prove that the required maintenance and testing have been carried out. (e.g. Majority of generators are maintained every 300 hrs and should have a sticker of last maintenance preformed attached to the side of it as reference).
- Generator fuel tank full and additional fuel available if required.
- Connecting cables for all three phases, neutral and earth are available and in serviceable condition. (Take particular care to ensure that Litton Veam connectors as in ES 319 are not loose.)
- Suitable cable end adapters are available and in good condition for connection to the load point.
- Ensure that cable terminations on generator are not loose, damaged or showing any signs of distress and when connected the termination fits in tight and securely.
- Correct trailer plate fitted and electrically connected so that all warning lights operate correctly.
- Electricity North West contact details for job left on site.
- Engine oil checked to correct level.
- Battery voltage at correct level.
- Water coolant at correct level.
- Trailer tyres inflated to correct pressure.
- The electric lead for recharging the battery and to operate engine coolant and alternator heaters is disconnected.

NOTE: that this may have been connecting to ensure smoother running of the diesel engine at start up. This is particularly applicable in cold weather.

- The towing pin and clip are in place before using trailers.
- The jockey wheel and support/stabiliser legs, where fitted, are fully raised and secured before towing trailer-mounted generators.
- Break away cable is fit for purpose and utilised.
- Any issues shall be rectified before the generator is deployed.

8.2.2 Vehicle Checks

The vehicle carrying or towing the generator to site shall be checked to ensure that it is in a roadworthy state.

8.3 Siting the Generator

Generators shall be sited as near as practical and Safely to the connection point to the system. Vehicle-mounted generators shall be parked, with the parking brake securely applied.

8.3.1 Generator Exhaust Fumes

Mobile generators can emit carbon monoxide (CO) which is a colourless, odourless, tasteless, poisonous gas that can cause death or serious harm. Possible signs of CO poisoning are flu-like symptoms, nausea and vomiting.

Mobile generators shall be positioned to keep exhaust fumes away from any possible entry points to buildings etc, such as windows, doors, air vents, flues, excavations or confined spaces. Consideration shall be given to the risk of Change of wind direction and speed diverting exhaust fumes. Mobile generators shall not be positioned in, small enclosed, gardens, yards or areas where there may be restricted airflow and the risk of gases building up that may seep into properties etc.

A carbon monoxide alarm shall be left with occupier of the property, if there is a risk of fumes entering their property.

The occupier shall be made aware of the position of the mobile generator and to contact Electricity North West immediately via contact details left on site to resolve any issues.

The Mobile generator shall be secured in position and a photograph taken of its position. When completing a POWRA any additional site-specific risks and the control measures applied for risks of CO shall be recorded. A mobile generator shall not be deployed if the POWRA highlights the location is not suitable for use.

8.3.2 Other considerations

Ensure the following when siting the generator:

- The potential hazard to other road users and the public is kept to a minimum.
- The ground is as level as possible.

Sept 24

- The wheels (where fitted) are turned towards the road edge when on an incline (where supplied with the generator, wheel chocks shall be used).
- Where fitted, support/stabiliser legs are lowered and secured.
- Where feasible, the cooling air exhaust louvers face away from any noise sensitive areas. Where noise pollution could be an issue, consider using acoustic panels.
- Ensure that the generator will have a good earth connection (refer to [Section 8.6](#)).
- Ensure that the neutral connection to the system will be:

As short as possible and connected as close as possible to the outgoing neutral conductor.

As secure and protected as possible, so that it cannot become damaged or disconnected during operation.

Where necessary, additional precautions shall be taken (as detailed in the relevant section below) to protect the public from any potential hazards such as:

- Open substation doors.
- Cables across the footpath, inside properties, etc.
- Obstruction from the parked vehicle.
- Heras Fencing surrounding the generator unit.
- This may include placing cones, barriers, lamps and/or warning notices.
- Work carried out under the New Roads and Street Works Act shall comply with CP102.
- Signing, lighting, guarding and diversions in line with the New Roads and Street Works Act are covered in the New Red Book: "Safety at Street Works and Road Works – A Code of Practice".

The latest Street Works Advice Note (SWAN) is shown below:



For security and safety, Heras fencing shall be considered.

If additional security measures are applied, ensure that they will not interfere with the mobile generator control panel. For example, ensure that an Emergency Trip button is available and is outside any fencing.

The possibility of leaving a generator unattended shall be considered for all cases. For planned work this shall be considered in advance of the actual job. During this assessment, the Generator Security Risk Assessment ([Appendix B](#)) shall be completed and the following points shall be taken into account:

- Potential hazards shall be minimised before it is safe to consider leaving the generator unattended.
- Trailer-mounted mobile generators shall be secured, possibly by chaining to a secure fence or pole, etc, to deter theft.
- Where an LV cabinet cannot be locked due to the generator connection, LV board shrouding sheets (to the same specification as LV board sheets) may be used provided they are fitted in such a way as to prevent access and provide weatherproofing. Danger notices shall be attached and clearly visible from all sides. If a generator connected in this manner is to be left unattended, removal of the shrouding shall not be possible as ratchet straps shall be locked off with the use of substation locks. The shrouding shall be inspected at a frequency determined by the risk assessment. Details of shrouding specification can be found in [Appendix E](#) of this CP.
- Additionally, substation doors that cannot be shut shall be secured by, for example, padlock and chains to prevent access.
- Suitable barriers or fencing shall be used to offer physical protection if required by the risk assessment in use.
- The Generator shall also have a fully-visible permit board attached if required. An emergency telephone number shall be clearly displayed. If fencing is used, ensure that the emergency telephone number is displayed on the outside of the fencing.
- If there are any doubts about safety or security, the generator shall not be left unattended.
- Where there are multiple generators that need to be attended, it may be possible for one person to periodically check them all (to be determined by the risk assessment).

8.4 Where Generator is Electrically Adjacent to Work

Where it is intended to work on part of the system electrically adjacent to the point where the generator is connected, the point(s) of isolation between the two parts of the system shall be clearly defined to ensure the generator cannot energise any HV or LV equipment isolated for work.

A Site Safety Co-ordinator shall be appointed (because there will be multiple Working Parties on site), and all such work shall be in accordance with the Distribution Safety Rules.

8.5 Inline Fusing / Circuit Breaker Module

Where required approved inline fusing or a circuit breaker module shall be installed between the generator and point of connection, both of which should be located as near as possible to the generator itself during installation. The generator supply will match that of the supply capacity on the section of network where the generator is connected to. It is very important that the protection grading applied of the inline fusing or circuit breaker module aligns with the protection parameters that are upstream of the point of connection.

8.6 Selecting/Preparing a Suitable Earth

Preferably, the generator shall be connected to a local Electricity North West LV Network earth (refer to [Section 8.6.1](#)), unless the generator is connected via an RCD as shown in [Appendix D](#). If a Network earth is not available (for example, no system earth within 25m) the generator shall be connected to a good earth mat (refer to [Section 8.6.2](#)).

A continuous earth shall be planned prior to connection. The earth must be continuous whenever the generator is operating, therefore, all work must be taken into account prior to connection. For example, if a cable being used as generator earth is to be cut, it will be necessary to strap across to maintain the earth.

At certain sites, for example, marinas and caravan sites, there are special requirements for earthing. Refer to CP332 for more information.

If the above conditions cannot be met, a generator shall not be used.

8.6.1 LV Network Earth

Do not connect generator to Network earth at this stage (the full connection procedure is covered in a later Section).

Wherever possible, the generator shall be connected to a local Electricity North West LV Network earth:

- Substation LV earth (likely to be combined with HV earth).
- PMT LV earth (likely to be separate from HV earth - beware of HV earth zone).
- LV cable sheath (at least 10m of uninsulated sheath).
- LV overhead 5th wire (confirm connected to earth).
- Industrial/domestic termination/cut-out. (Note that for single-phase only, an earth is not required if an RCD is used as per [Appendix D](#).)
- Before connecting the generator to an Electricity North West LV Network earth, the integrity of this earth shall be confirmed. The points of connection shall be carefully selected to ensure that any proposed work does not compromise the earth or neutral of supplies being maintained by the generator.
- Where the HV and LV earths are separated, the generator earth cable shall not encroach within a minimum 3m radius (preferably within a 10m radius) of the earth connection of the system earth to which the generator is NOT being connected. Where the generator earth cable, as a result of the location of the generator, needs to pass through this earth zone, the earth cable shall be insulated.

8.6.2 Temporary Earth Mat

Where it is impractical to connect to an Electricity North West Network earth, a temporary earth mat shall be constructed. The temporary earth shall consist of 4 earth rods driven into the ground and connected in a star formation as with temporary overhead line earths. Note that a minimum of 90% of each rod must be driven into the ground before this temporary earth mat can be used as an earth.

Care shall be taken to ensure that there are no underground utility services (cables and pipes) or other installations which may be damaged by driving these rods into the ground. For more details see CP430 Part 1. This earth mat shall be placed away from the Immediate working area, and may need to be barriered off, so that it does not become a tripping hazard. A caution notice shall be attached to the earth.

8.7 Pulling Out, Inspecting and Protecting Cables

8.7.1 Pulling out Cables

Pull out the cables and lay in position prior to making connections, taking the following into account:

- Care shall be taken to avoid damaging the connectors or abrading cables by scraping them along the ground.
- Pulling out cables may need two people depending upon the size of cables. (Only one person should be required for leads used with generators of 10kVA and less.)
- Only one cable shall be handled at a time.

8.7.2 Inspecting Cables

Inspect cables to ensure:

- The inner insulation cover is not visible and connector connections are sound. If the generator power output is greater than 10kVA, the inspection shall be carried out by an Authorised Person.
- All cable connections shall be via a suitably rated, insulated, waterproof and colour-coded proprietary connector.

Protecting Cables

- Where necessary, physically protect the cables (and prevent a trip hazard) where reasonably practicable using pathboards, cable guards or appropriately rated ramps. This is mandatory across public access routes.

8.8 Connecting the LV Cables to the Generator

8.8.1 Preparation

Refer to [Appendix C](#) for new and old colour coding before making any connections.

Prepare to connect LV cables to the generator as follows:

- Before making or breaking any cable connection, with the exception of the final connection/disconnection to/from the system, ensure that the generator is switched off and has stopped running.
- Ensure that the generator LV circuit breaker is open (which also opens the neutral circuit) locked off where practicable, and caution notice posted on the generator control panel before handling any connections.

8.8.2 Connection

Do NOT make final connections to LV system apparatus yet.

Make intermediate connections on all cables, including the earth and neutral cables, before connecting any cables to the generator.

Make all the connections to the generator output panel sockets in the following order:

- (a) Earth cable.
- (b) Neutral cable.
- (c) Phase cable(s).

8.9 Connecting LV Cables from the Generator to the Electrical Distribution System Apparatus

8.9.1 Point-of-Work Risk Assessment

A new point-of-work risk assessment shall be completed at this point (ie immediately prior to making final connections and operating the generator).

8.9.2 Background Information

8.9.2.1 General

Refer to [Appendix C](#) for new and old colour coding.

Ensure that there is adequate room to carry out the operations included in this section. This is particularly important for Live operations. Ensure, for example, that there is enough room to complete Live switching operation before starting (for example, switch handle will be free to move all the way without being blocked when operating the LV isolators). Ensure any small-scale embedded generation is isolated before making any connections (to avoid the possibility of reverse power flow), and remains isolated until the mobile generator has been disconnected. If it is proposed to synchronise the generator to the LV system to avoid interrupting supplies to connected customers and the connecting of the generator cables to the system apparatus can be undertaken safely in accordance with the following procedure, then the Live connections may be made. If all the following conditions cannot be met, the connection shall be made with the system Dead.

Before making any connection, the electrical distribution system earth, neutral and phase terminals shall be tested using test lamps or a volt meter to confirm that the earth, neutral terminals and all phases are healthy. If the system is Dead, the neutral and phases may have been marked up at the substation. In either case,

neutral and phases will be confirmed as soon as the generator is operating. Refer to [Section 8.9.2.2](#) regarding guidance on access and testing procedure. .

Fully screened LV cabinets and boards fitted with test sockets (that have been modified or have existing fused leads) are restricted to use by Generator Operators only using appropriate test plugs. Test lamps fitted with longer probes shall only be used for testing across transformer links. Prior to making any Live connection, the generator LV circuit breaker (switch) shall be confirmed open and if the connection is being made in a substation then the lock on the trip handle of the switch controlling the local transformer shall be released, if applicable, provided there are no Operational Instructions in place preventing this. Any lock removed shall be replaced on completion of the job. Only an accompanied Authorised Person may make these Live connections wearing PPE specified in [Section 4.1.2](#).

8.9.2.2 Access and Testing (at Customer Premises)

The following (as applicable) shall be checked out as soon as is practicable after energisation by the generator:

- Voltage.
- Polarity, neutral and earth loop.
- Phase rotation by testing correct operation of a three-phase piece of equipment.
- In some cases it will be difficult to contact relevant people and gain access to premises. However, every effort shall be made to contact the relevant people and ensure that the relevant checks are carried out as soon as possible. (Where it is not possible to carry out these checks immediately after energisation at an appropriate point on the system then a risk assessment will be conducted by the authorised person prior to re-energisation. This risk assessment will determine whether supplies are to be left off due to there being no access to an appropriate point on the system to confirm checks or whether by confirmation of the system running arrangements the generator can be energised and these checks be carried out at the next earliest opportunity if applicable).

When attempting to gain access to properties, consider the following:

- A neighbour may know when the property holder is due to return.
- A neighbour may be a key holder.
- For commercial properties the police may have the telephone number of the key holder.

8.9.2.3 Limits of Work on Meter Terminals, Cover and Consumer Unit

The following limits of work/rules apply to meter terminals, cover and consumer unit:

- Meter cover and tails may be removed. (An approved tool shall be used to re-seal the meter terminal cover.)
- Customer Consumer Unit – the ON/OFF switch may be operated.
- Customer Consumer Unit – covers may NOT be removed.

- It is NOT permissible to work on the customer's wiring or connections.

8.9.3 Connection Procedure

8.9.3.1 General

This connection procedure refers to making connections Live. If the connections are to be made Dead, omit the steps that refer to making connections Live.

The connections shall be made by an Electricity North West authorised person.

Provided the above checks and rest of conditions in [Section 8.8](#) above are met, the following connections may be made Live by an Authorised Person wearing PPE specified in [Section 4.1.4](#).

When making a Live connection to the LV system, use an approved wedge tightening proprietary connector with an insulated handle and tightening mechanism designed for the application, or an approved alternative.

Repeat the check in [Section 8.9.2.1](#) immediately before any Live switching operation, (ie) ensure there is enough room to complete the switching operation before starting (for example, switch handle will be free to move all the way without being blocked when operating the LV isolators), and ensure the operating handle is in good condition.

Refer to [Appendix E](#) for typical supply restoration procedures using generators.

8.9.3.2 Making Connections

Confirm generator LV circuit breaker is open, locked (where practicable) and caution notice posted.

Make connections in the following order (it is particularly important to ensure that earth and neutral connections are electrically good and are secure):

- (a) Earth cable.
- (b) Neutral cable (it is particularly important to ensure that the neutral cannot be become damaged or disconnected during operation of the generator).
- (c) Phase cables.

If making the connections Live, carry out the Additional Steps in [8.9.3.3](#) below,

If making connections Dead, remove the caution notice and/or lock on the generator LV circuit breaker.

8.9.3.3 Additional Steps if Connecting Live

If connecting Live, proceed as follows:

- Check the load and phase rotation and pass the information to the Third-Party Generator Operator who will then synchronise the generator to the Network under the supervision of the Electricity North West authorised person.
- Remove the caution notice and/or lock on the generator LV circuit breaker.

- Close the LV circuit breaker on the generator.
- Confirm that the load has been picked up by the generator. This can be done by either:
 - Clipping the T/F tails or links, or
 - Where the LV board is fully or part shrouded, summing all LV feeder loads.
- Provided the load has been picked up, open each of the LV phase isolators in turn, smartly, fully, and with minimum delay between each operation. (Note that each operation must be taken to completion once started – Do not attempt to reclose.)
- Lock LV isolators and post caution notice.

8.10 Operating/Monitoring the Generator

In the case of a known LV fault that has not been isolated, and a generator is connected to a customer's termination (ie Mod Panel or cut-out), the authorised person must monitor the fault condition for any change, for example, the neutral becoming Live or loss of other phases.

No earth shall be interfered with whilst there are temporary phase or neutral connections to the system.

Refer to the Supplier's manual for operation and refuelling, etc.

8.11 Disconnecting the Generator

Refer to the appropriate procedure in [Appendix E](#) and after the generator has stopped and the appropriate tests have been completed, the Accompanied Authorised Person wearing appropriate PPE, shall disconnect cables from the LV system in strict order:

- (a) Phase cables.
- (b) Neutral cable.
- (c) Earth cable.

Disconnect cables from generator in order:

- (a) Phase cables.
- (b) Neutral cable.
- (c) Earth cable.

Break intermediate connections on all cables (all cables disconnected from system and generator).

Inspect cables to ensure the inner insulation cover is not visible and connectors are sound as cables are restored to their reels or the cable storage panniers.

8.12 Return of Generator, Post-Use Checks and Maintenance

Part 2 of the Request for Mobile Generator Form ([Appendix A](#)) shall be completed by the person responsible for operating the generator on site and shall be returned, together with the generator delivery receipt, to the co-ordinator.

Upon return to the depot:

- Connect the generator to a 240V mains supply to power thermostatically controlled engine and alternator heaters and to recharge the batteries. This will prevent the coolant and fuel freezing in winter and will ensure that the engine starts reliably at all times on demand.
- Report any defects generator supplier and line manager.

Carry out pre-check maintenance in accordance with the Supplier's manual.

9 Documents Referenced

DOCUMENTS REFERENCED	
Electricity at Work Regulations 1989.	
Electricity Safety, Quality and Continuity Regulations 2002.	
New Roads and Street Works Act 1991.	
BS 5467:	Electric cables. Thermosetting insulated, armoured cables of rated voltages of 600/1 000 V and 1 900/3 300 V for fixed installations. Specification
ENA ER G84:	Recommendations for the connection of mobile Generating Sets to public distribution networks
EPD613:	Strategy for the use of Mobile Generators
CP332:	LV Service Connections & Application of PME.
CP430 Part 1:	Overhead Line – Linesmen's Manual – Wood Pole
CP102:	New Roads and Street Works Act
CP411 Pt1N:	Mains Practice up to and Including 132kV – Cable Jointing Up To and Including 1000V
CP606:	Operations Manual
CP614:	Authorisation

CP618:

LV Supply Restoration – Strategy and Methods

10 Keywords

Generator; Restoration.

Appendix A – Request for Mobile Generators and Record of Use

Complete Part 1 and send to:

1	<p>From (Please print details)</p> <p>Day & date required (Attach plan/street map)</p> <p>Location</p> <p>Time required on site</p> <p>Time required off site</p> <p>Number of customers to be supplied</p> <p>Connection point</p> <p>Reason for use of generator</p> <p>O/H maintenance U/G maintenance Plant maintenance O/H fault U/G fault Plant fault</p> <p>Special Instructions</p>	<p>Intel</p> <p>Cost code</p> <p>Rating of generator required 1500/1250/1000/500/320/ 200/100/50 kVA Other</p> <p>Source Electricity North West / Generator Power</p> <p>New business Asset replacement/renewal Reinforcement NTR work Request by third party Other (please specify)</p>
2	<p>Time generator on load</p> <p>Time generator off load</p> <p>Mean load kVA</p> <p>Total Hire Charge £ (If applicable)</p> <p>kWh of generation kWh</p> <p>Gas oil consumption litres</p> <p>Total man hours with generator paid hours (including travel, connection, operation, attendance, refuelling etc.)</p>	

Appendix B – Generator Security Risk Assessment

Generator Security Risk Assessment				
<i>Mobile Generator to be sited, leads run out and connected as per CP613</i>				
Substation / PMT Name or Pillar / Linkbox No.				
Indoor / Outdoor / PMT		Address		
CHECKS to be made to ascertain if generator can be left on site unattended				
Site checks - position of generator		Tick appropriate box		Action reqd
Environment	Urban	Suburban	Rural	
Highway	Main	Secondary	Track	
Footpath	Wide	Narrow	None	
Other location	Car park	Grass verge	Field	
Access / Egress for :	Vehicles	Pedestrians	Animals	
Security situation	Open to public	Private land	Secure site	
Clearances correct from :	substance.	O/H line	equipt.	
Other:- write in				
Visual check of Generator and leads		Tick appropriate box		Action reqd
Emergency Stop Button	Lockable	Not lockable		
Leads Inspected	Sound	Unsound	Support reqd	
Connections Inspected	Sound	Unsound	Support reqd	
Earth pins	Present	Not present	Trip hazard	
Fuel in tank	Low	Medium	High	
Access doors	Lockable	Not lockable		
Trailer	Brake applied	Legs down	Chained up	
Notices posted	Caution	Danger	Contact No.	
Environmental checks		Tick appropriate box		Action reqd
NRSWA requirements	Cones	Barriers	Lights	
Pollution risk from Oil	Low	Medium	High	
Noise and fume levels	Low	Medium	High	
Interference and Safety checks		Tick appropriate box		Action taken
Vandalism risk		Low	High	
Theft risk		Low	High	
Unauthorised access to S/S		Low	High	
Significant risk to public		Low	High	
Significant risk to animals		Low	High	
Substation / PMT access	Normal locking	Temporary lock	Harris fencing	
Comments				
Having considered all the above, decision has been taken to leave generator unattended:				
Signature		Print		

Electricity North West POWRA



Job / Project	WI/Fault No.	Date of Work:			
Location (Circuit/PMT/Substation):					
Site Address (inc. Post Code or Grid Reference):					
Nearest A&E:					
Task(s) to be carried out:					
High Risks: (tick any relevant):					
Work at height	<input type="checkbox"/>	Live LV work	<input type="checkbox"/>	Dead work	<input type="checkbox"/>
Breaking conductors	<input type="checkbox"/>	Exposed live HV	<input type="checkbox"/>	Asbestos / hazardous	<input type="checkbox"/>
Lifting operations	<input type="checkbox"/>	Stored energy	<input type="checkbox"/>	Chainsaws / cutting	<input type="checkbox"/>
Breaking ground	<input type="checkbox"/>	Powered plant /	<input type="checkbox"/>	Confined space	<input type="checkbox"/>
Excavation / work at depth	<input type="checkbox"/>	Trainees on site	<input type="checkbox"/>	Multiple working parties	<input type="checkbox"/>
Are the risks associated with the task(s) adequately managed by standard operating procedures i.e. Distribution Safety Rules / Codes of Practice / Training? If YES then proceed to significant site hazards section. If NO, a task specific risk assessment must be completed and documented below.					Yes
Risks associated with the task(s) not adequately managed by standard operating procedures			Controls to be implemented		

Significant site hazards (tick if present and then detail below):

Adverse weather /		Vehicles /plant /		Railways	
Access on and off site		Traffic / pedestrians		Deep water	
Ground conditions		Restricted access or		Environmental impact	
Members of public		Edges, slopes or drops		Other works	
Animals / Wildlife		Possible violence		Other hazards	

Detail of significant site hazards	Controls implemented

Risk Assessment Completed by (Member of Working Party)

Name:	Sign:	Date:	Time:
-------	-------	-------	-------

Site Co-ordinator (for sites with more than one working party)

Name:	Sign:	Date:	Time:
-------	-------	-------	-------

Working Party / Visitor Sign On

Name:	Sign:	Date:	Time:
Name:	Sign:	Date:	Time:
Name:	Sign:	Date:	Time:
Name:	Sign:	Date:	Time:
Name:	Sign:	Date:	Time:
Name:	Sign:	Date:	Time:

Appendix C – Cable Colours

Reference shall be made to this Appendix prior to making any connections.

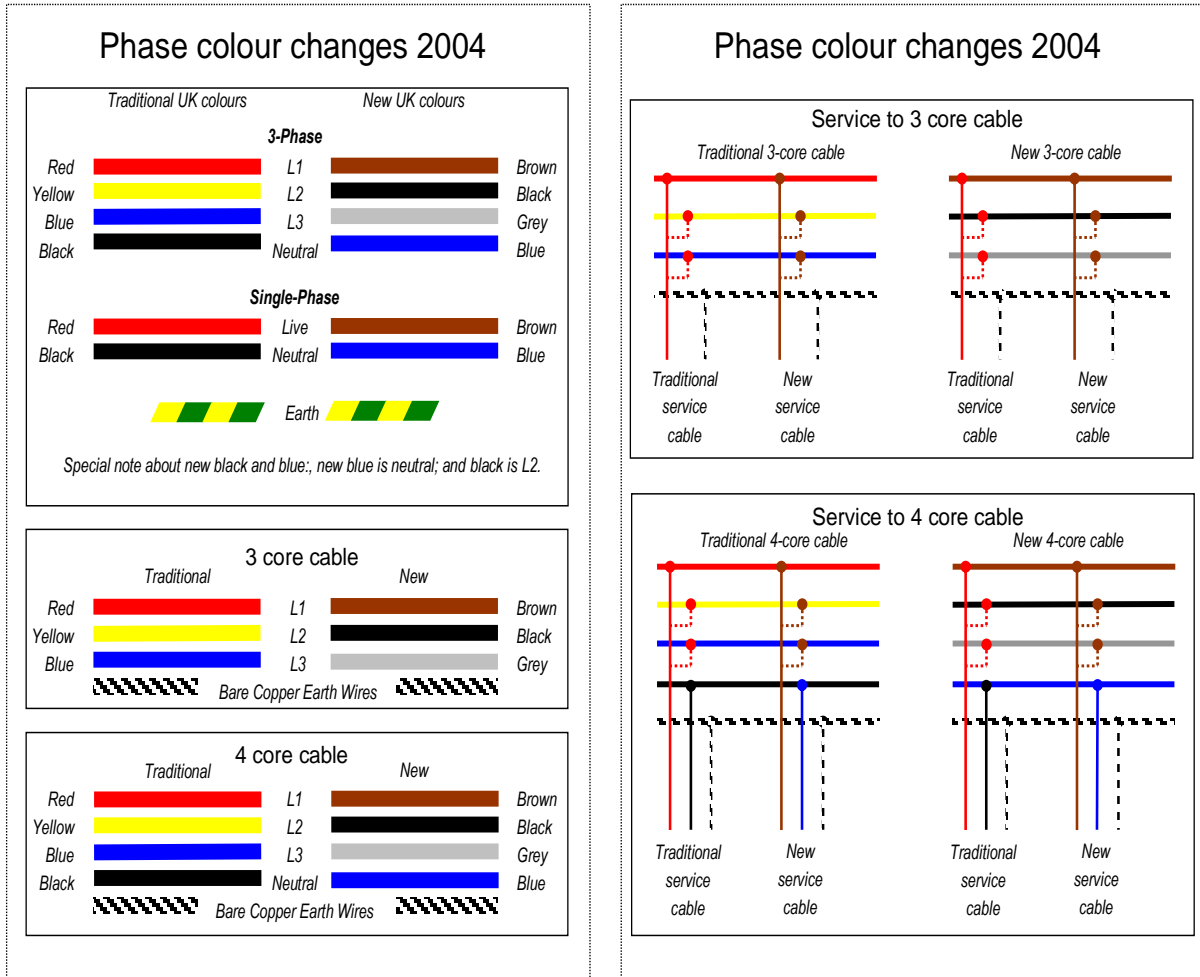

Appendix D – Typical Procedures for Connecting Small Generators to Single-Phase Consumers

The two procedures detailed below contain the basic steps only. For detailed information on each step (where applicable) refer to the corresponding text in the main document.

D1 Connection of Suitcase Generator

Fig. D1 Connection of Suitcase Generator to Single-Phase Customer

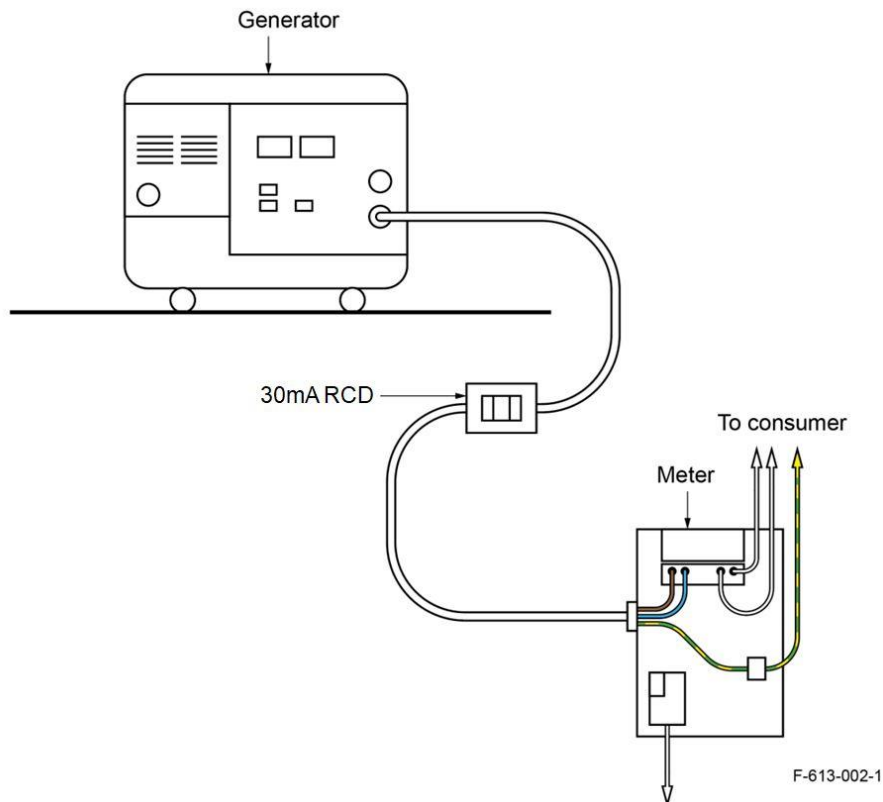

D1.1 Procedure

Refer to [Fig. D1](#) and proceed as follows.

D1.1.1 Carry out a Risk Assessment

Carry out an on-site risk assessment (including physical protection of the flex).

D1.1.2 Secure and Keep the Generator Safe

During set up and operation, ensure the following:

- The generator is guarded or is within a barriered area to safeguard the public at all times.
- If possible chain the generator up to prevent theft.

D1.1.3 Confirm the Customer's Consumer Unit is in the OFF Position

Confirm the customer's consumer unit is in the OFF position before commencing work.

D1.1.4 Connect the Generator to the Consumer Unit

It is important that the following steps are carried out in the order specified.

Ensure there is a 30mA RCD connected in the position shown in [Fig. D1](#) and proceed as follows:

- Remove main fuse from cut-out.
- At the cut-out position completely remove the meter tails from the cut-out and meter. Remove the earth connection from the cut-out.
- Ensure incoming terminal is made inaccessible by reinserting a blank fuse carrier or rubber patching to ensure no Live contacts are accessible when the fault is repaired and the service is re-energised.
- Terminate the green/yellow wire from the generator flex in an earth block on the meter board.
- Terminate the blue neutral wire from the generator flex in the neutral meter terminal.
- Terminate the brown Live wire from the generator flex into the Live meter terminal.
- Connect the blue plug into the generator and start the generator up.
- Apply thin rubber sheeting to cover whole of meter board and attach Danger Notice.
- Wait a minute for the generator to warm up. Check no load volts.
- Ensure all of the customer's appliances are unplugged/switched OFF.
- Test operation of the RCD and switch the customer's consumer unit ON *.
- Check polarity at a socket before any load is connected – up to 2kW – advise customer.
- Where difficulties are experienced due to customer's installation, braided flex with 13A sockets fitted may be utilised.

* If the RCD trips, do not adjust the sensitivity. Disconnect the generator and tell the customer that there is a safety issue with their earth, and they must get it repaired by a qualified electrician before any other electrical equipment is connected.

D2 Connection of Small Generator (Up to 10kVA)

Fig. D2 Connection of Small Generator to Single-Phase Customer

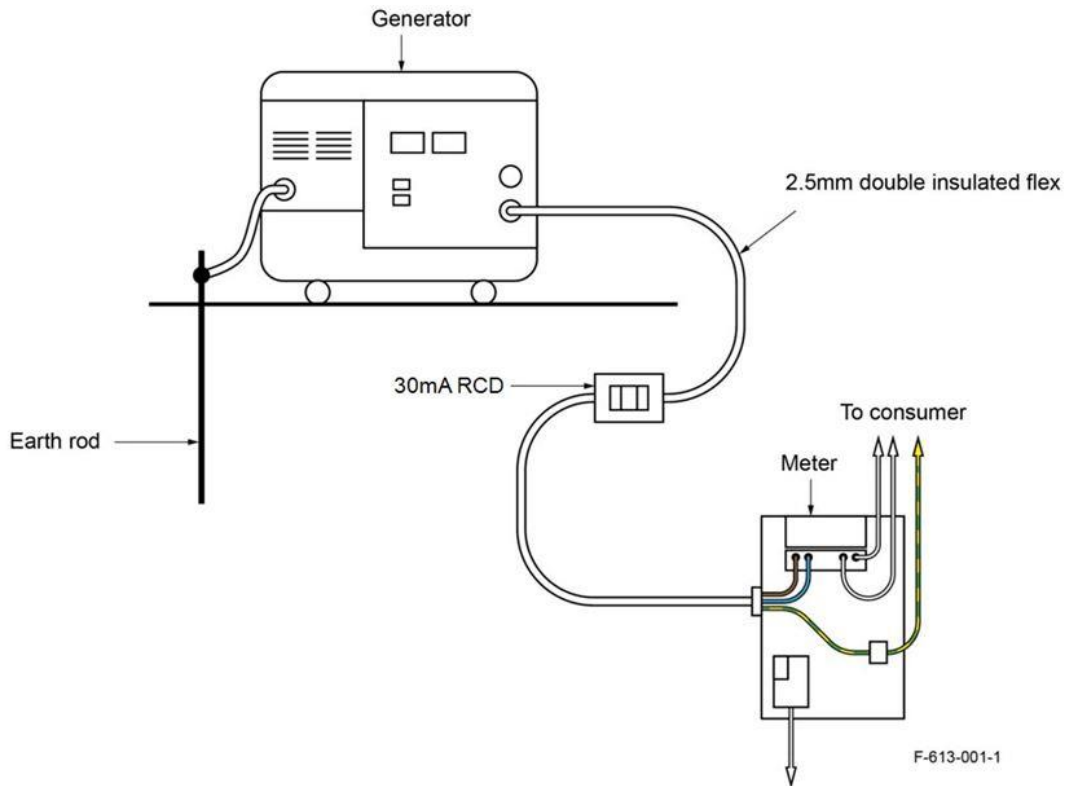

D2.1 Procedure

Refer to [Fig. D2](#) and proceed as follows.

D2.1.1 Carry out a Risk Assessment

Carry out an on-site risk assessment (including physical protection of the flex).

D2.1.2 Secure and Keep the Generator Safe

During set up and operation, ensure the following:

- The generator is guarded or is within a barriered area to safeguard the public at all times.
- If possible chain the generator up to prevent theft.

D2.1.3 Insert and Connect the Earth Rod

- Insert the earth rod provided in the ground and connect it to the earth terminal on the generator.
- Post a caution notice on the earth rod connection.

D2.1.4 Confirm the Customer's Consumer Unit is in the OFF Position

Confirm the customer's consumer unit is in the OFF position before commencing work.

D2.1.5 Connect the Generator to the Consumer Unit

It is important that the following steps are carried out in the order specified.

Ensure there is a 30mA RCD connected in the position shown in [Fig. D2](#) and proceed as follows:

- Remove main fuse from cut-out.
- At the cut-out position completely remove the meter tails from the cut-out and meter. Remove the earth connection from the cut-out.
- Ensure incoming terminal is made inaccessible by reinserting a blank fuse carrier or rubber patching to ensure no Live contacts are accessible when the fault is repaired and the service is re-energised.
- Terminate the green/yellow wire from the generator flex in an earth block on the meter board.
- Terminate the blue neutral wire from the generator flex in the neutral meter terminal.
- Terminate the brown Live wire from the generator flex into the Live meter terminal.
- Connect the blue plug into the generator and start the generator up.
- Apply thin rubber sheeting to cover whole of meter board and attach Danger Notice.
- Wait a minute for the generator to warm up. Check no load volts < 253V, if not adjust engine speed control.
- Ensure all of the customer's appliances are unplugged/switched OFF.
- Test operation of the RCD and switch the customer's consumer unit ON *.
- Check polarity at a socket before any load is connected – up to 5kW – advise customer.

* If the RCD trips, do not adjust the sensitivity. Disconnect the generator and tell the customer that there is a safety issue with their earth, and they must get it repaired by a qualified electrician before any other electrical equipment is connected.

Appendix E – Typical Procedures & Equipment for Supply Restoration Using Generators

The procedures detailed below contain the basic steps only. For detailed information on each step (where applicable) refer to the corresponding text in the main document.

E1 LV Generator Connection to Low Voltage Cables

This procedure enables three-phase generators to be connected to three-phase low voltage cables. All generators can be connected on to cables up to 300mm² using approved 600A insulated cable connectors. Refer to CP411LV Procedure 3/405 for details of how to achieve this over the full range of connection options.

E1.1 Initial Assessment Points for Consideration

- Availability/amount of resources required to repair fault and restore supplies.
- Estimated time to complete repair.
- Number of customers affected and anticipated load.
- Size of generator required.

E1.2 Location of Excavation shall take into Account:

- Cable records (position of joints etc).
- Siting of the generator.
- Public safety.
- Fault location.

E1.3 Preparation of Cable for Generator Connection

- Excavate sufficient ground to cater for straight joint and installation of earth rods.
- Identify the cable at point of work and strip cable for straight joint using Live jointing techniques (CP411LV).
- Cut cores and neutral and temporary bottle end cable back to source of supply.
- In the case of 4 core cables it will be necessary to identify the neutral, possibly requiring techniques detailed in CP606/610. If the neutral cannot be identified at that point, consideration shall be given to connecting the generator at a three-phase customer's service position. (If feeding the Network from this position, the conductors would need to be rated for the load.)
- Install earth rods to provide a generator earth connection and a connection to the sheath of the cable to be supplied by the generator. (Refer to [Section 8.5](#) for further earthing requirements.)

E1.4 Connecting Generator Leads

- Run out and inspect generator leads. Connections to be made in sequence.
- Connect generator leads to cable conductors using approved connectors. Fit temporary joint cover, which is available as stores item, to provide mechanical protection.
- Physically protect the cables where reasonably practicable (pathboards or cable guards).
- Connect cables at generator.

E1.5 Operation of Generator

- All generators shall be operated in accordance with specific manufacturer's instructions.
- Check polarity and phase rotation at a suitable three-phase supply. (Where it is not possible to check phase rotation immediately after energisation at an appropriate point on the system then a risk assessment will be conducted by the authorised person prior to re-energisation. This risk assessment will determine whether supplies are to be left off due to there being no access to an appropriate point on the system to confirm correct phase rotation or whether by confirmation of the system running arrangements the generator can be energised and phase rotation be checked at the next earliest opportunity if applicable).
- If found to be incorrect switch off generator and correct lead connection at joint position. Switch on generator and confirm polarity and phase rotation are correct at same reference point.
- Restore supplies to any three-phase customers previously isolated.
- A Competent Person shall remain on site at all times.

E1.6 Disconnection of Generator

- Where practicable, before switching off the generator, inform customers that supplies are to be removed whilst the final joint is completed.
- Switch off generator and disconnect leads at the generator.
- Disconnect generator leads at straight joint position.
- Make permanent repair straight joint using Live techniques.
- On completion confirm customers supplies restored.

E1.7 LV Shrouding Specification for Outdoor Plant Left Unattended

Equipment Items

- Large LV shroud
- 2 x Ratchet strips

- ENWL Contact details signage
- Velcro Danger notice straps

E2 LV Generator Connection to/from any De-energised Network

E2.1 Procedure

- Confirm generator engine is not running.
- Confirm generator LV circuit breaker open, lock control panel (where appropriate) and post caution notice.
- Select 3-phase or single-phase as required. It is very important that this is not overlooked.
- If split phase is required, this needs to be specified by the generator supplier.
- Ensure LV network is de-energised. All points of isolation shall be safety locked, where appropriate and a caution notice posted.
- Connect generator leads in accordance with the Safety Rules and using Live techniques and the appropriate connectors.
- Start generator and set voltage at 245V, frequency at 50Hz and power factor at 1. Then close generator LV circuit breaker. If the load is too great for connecting in one step consider splitting the load by removal of fuses and increasing load on the generator in stages.
- Adjust the generator output to optimise voltage and frequency as close as possible to the settings given in the above step. The voltage may be reduced to 240V if necessary to maintain current within rating of the generator.
- Check phase rotation at a suitable three-phase supply. (Where it is not possible to check phase rotation immediately after energisation at an appropriate point on the system then a risk assessment will be conducted by the authorised person prior to re-energisation. This risk assessment will determine whether supplies are to be left off due to there being no access to an appropriate point on the system to confirm correct phase rotation or whether by confirmation of the system running arrangements the generator can be energised and phase rotation be checked at the next earliest opportunity if applicable).
- If found to be incorrect, switch off generator and correct lead connection at joint position. Switch on generator and confirm polarity and phase rotation are correct at same reference point.
- When work is complete:
 - Check supplies are healthy.
 - Open generator LV circuit breaker and lock control panel (where appropriate) and post caution notice.
 - Stop generator.

- Test to prove circuit not Live.
- Disconnect generator leads in accordance with the Safety Rules and using Live techniques.
- Restore LV system to normal running arrangement.
- Stow connecting cables safely and tidily for next time.

E3 LV Generator Synchronised Connection to/from Energised Network

E3.1 Procedure

- Confirm generator engine is not running.
- Confirm generator LV circuit breaker open, lock control panel and post caution notice.
- Check 3-phase operation selected.
- Test LV network to identify neutral and prove healthy. Check phase rotation.
- Connect generator leads in accordance with the Safety Rules and using Live techniques and the appropriate connectors.
- Confirm correct connection, of phase leads in particular.
- Confirm load and phase rotation correct. Check phase rotation at a suitable three-phase supply. (Where it is not possible to check phase rotation immediately after energisation at an appropriate point on the system then a risk assessment will be conducted by the authorised person prior to re-energisation. This risk assessment will determine whether supplies are to be left off due to there being no access to an appropriate point on the system to confirm correct phase rotation or whether by confirmation of the system running arrangements the generator can be energised and phase rotation be checked at the next earliest opportunity if applicable).

The Third-Party Generator Operator shall then synchronise the generator to the Network under the supervision of the Electricity North West Engineer.

NOTE: that only the Generator Operator may carry out the synchronisation procedure and this must only be done under supervision.

- Ensure the generator has picked up the load.
- Open infeed from mains network, if required, and post safety lock and caution notice.
- Adjust the generator output to optimise voltage and frequency as close as possible to the settings given in Procedure E2.1 (ie 245V, 50Hz). The voltage may be reduced to 240V if necessary to maintain current within rating of the generator.

When work is complete to synchronise back onto the network:

- Check that supplies from both the network and the generator are healthy.

- Connect the synchronising panel across the network switch where the synchronised parallel is to be made using Live techniques. Only an accompanied Authorised Person may make these Live connections wearing PPE specified in [Section 4.1.4](#).
- Check the loads are not fluctuating excessively. High fluctuating loads may cause the generator to move in and out of synchronisation with the network. No attempt shall be made to synchronise if the generator isn't holding in synchronisation sufficiently long enough. It may be possible to wait until the loads are not fluctuating excessively or alternatively the generator will need to be disconnected and normal restoration procedures followed.
- Confirm when the synchronising panel is indicating the generator is in synchronisation with the network by phasing out using approved test lamps across the generator/network. This will confirm the synchronising panel is providing the correct indication of the generator being in synchronisation with the network.
- Ensure before synchronising, the Authorised Person and Third-Party Generator Operator shall be in clear and direct communication (nearby within sight and sound) to confirm the generator is in synchronisation with the network. With some LV board types, the reference lead may need to be removed when closing the final LV isolator. This shall be discussed between the Authorised Person and the Third-Party Generator Operator.
- When in synchronism, close switch, one blade of knife switch, or insert fuse on one phase. This will lock in synchronism whilst remaining phases are closed. (Remaining blades and fuses should be closed without delay). The order in which they are closed should be agreed with the Third-Party Generator Operator.
- Reduce generator load to zero and open LV circuit breaker, lock control panel and post caution notice.
- Test LV network to prove healthy.
- Stop generator.
- Disconnect generator leads in accordance with the Safety Rules and using Live techniques.
- Stow connecting cables safely and tidily for next time.