



## **Code of Practice 319**

**Issue 1      November 1999**

# **Applied High Voltage Tests**

## **Contents**

- 1    Scope
- 2    Quickfinder guide to tables
- 3    Foreword
- 4    Voltage testing of cables
- 5    Voltage testing of switchgear
- 6    Voltage testing of voltage and current transformers
- 7    Voltage testing of transformers
- 8    Standards referenced
- 9    Keywords

## **Authorised for issue by the Standards Steering Group**

© 2010 Electricity North West Limited.

All Rights Reserved

The copyright of this document, which contains information of a proprietary nature, is vested in Electricity North West Limited. The contents of this document may not be used for purposes other than that for which it has been supplied and may not be reproduced, either wholly or in part, in any way whatsoever. It may not be used by, or its contents divulged to, any other person whatsoever without the prior written permission of Electricity North West Limited.



Amendment Summary

Amendment No. Date	Brief Description and Amending Action
0 01/11/99	Issue 1 First Issue Prepared by: Simon Rushton                      Authorised by:
1 12/08/03	Issue 1 Rebranded with United Utilities logo. Paragraph 3. amended for Electricity Safety, Quality and Continuity Regulations Prepared by: John Sullivan.                      Authorised by: Ellis Wilkinson on behalf of The Standards Steering Group.



## VOLTAGE TESTING CODE OF PRACTICE

### 1. SCOPE

This Code specifies the voltages and time durations for the testing of plant and cables from 400/230 V to 132 kV. Guidance is also given on safe procedures and precautions for carrying out testing work.

### 2. QUICKFINDER GUIDE TO VOLTAGE AND TIME DURATION TABLES

#### Cables

400/230 V new & previously in service	Table 1	Page 3
6.6/11kV new	Table 2A	Page 5
6.6/11 kV previously in service	Table 2B	Page 6
33 kV new	Table 3A	Page 7
33 kV previously in service	Table 3B	Page 7
132 kV new & previously in service	Table 4A	Page 8
132 kV single core polymeric	Table 4B	Page 8
Maximum impulse values	Table 5	Page 9
Sheath test voltages	Table 6	Page 9
Cable sheath voltage limiters	Tables 6A/6B	Page 10

#### Switchgear

New	Table 7A	Page 13
Previously in service	Table 7B	Page 14
Vts and cts new	Table 8A	Page 16
Vts and cts previously in service	Table 8B	Page 16

#### Transformers

New and previously in service	Table 9	Page 18
-------------------------------	---------	---------

### 3. FOREWORD

This Code of Practice supersedes the Code of Practice 19/2 issued in August 1989 including all amendments to that Code. It specifies testing procedures for both plant and cables, together with the required voltage test levels and durations.

Unlike the 1937 Electricity Supply Regulations, the Electricity Safety, Quality and Continuity Regulations 2002 make no specific reference to voltage testing of plant or equipment. However Regulation 3.(1) requires that “Generators, distributors and meter operators shall ensure that their equipment is.....used and maintained as to prevent danger, interference with or interruption of supply, so far as is reasonably practicable.” Electricity North West will discharge this obligation by testing high voltage plant and cables when first put into commission or at a later date, if the insulation has been worked upon or altered in any way.

#### 3.1 Technical background to testing

It should be appreciated that high voltage testing of new plant and cables on site supplements high voltage testing at the manufacturer’s works. Works testing will include both witnessed type testing of new designs and routine testing of all production, in accordance with the IEC or British Standard to which the plant or cable is manufactured. In the case of cables or plant not specified in this Code, the manufacturing standard should be consulted.

On-site testing of new equipment is mainly concerned with proving that the plant assembly and the high voltage cable jointing and termination have been carried out satisfactorily and that no damage has occurred whilst the plant was in transit, or in the case of cables, whilst laying. For 132 kV cables having insulated oversheaths, the commissioning voltage tests should also include an oversheath voltage test, to ensure that the oversheath is in good condition.

System earthing conditions affect voltage testing. The Electricity North West 132 kV system is classified as effectively earthed because the neutral points are solidly connected to earth, hence the maximum conductor to earth voltage cannot exceed 80% of the system voltage. Most of Electricity North West 6.6/11 kV systems are not effectively earthed, because the neutral points are connected to earth through impedances. These factors have been taken into account in formulating the tables.

For cables, limits are imposed for impulse voltage testing during fault location procedures and these limits are specified in the relevant section of this Code.

The voltage levels and durations of on site tests specified in the tables of this Code are mainly based upon the relevant IEC or BS specifications (where the standard specifies an on site test). For 6.6, 11 and 33 kV cables previously in service, where the condition of the insulation may have deteriorated, reduced voltage levels are applicable. These have been agreed with the cable manufacturers.

In AC testing, the applied voltage shall normally be 50 Hz, though in special circumstances a higher or lower frequency, or other waveform may be applied after obtaining the approval of the Electricity Operations Policy and Standards Manager. In general, AC 50 Hz testing is preferred because it stresses the plant or cable insulation in the same manner as it will be stressed whilst in service. Unfortunately, the capacitance of power cables of any length makes the reactive kVA required much too great to be supplied by equipment of reasonable size and cost, hence DC, VLF or resonance testing must be used instead.

Special cable diagnostic tests may also be carried out at the same time as AC voltage testing for example:

(a) Measurement of partial discharge (PD), including partial discharge mapping. PD mapping can be used to assess the quality of individual cable joints and the general condition of sections of paper insulated cable. A partial discharge free AC source is required for this technique.

(b) Measurement of the dielectric loss angle. This measures the quality of the entire cable circuit including the cable joints and terminations, but provides no specific information about any particular cable section or cable joint.

High voltage testing is dangerous and it must be carried out strictly in accordance with Electricity North West Electricity Safety Rules, policy and procedures. In all cases, records of testing must be made at the time of test and stored for future reference. The purpose of these records is to provide traceability should problems occur in the future.

#### 4. VOLTAGE TESTING OF CABLES

##### 4.1 Voltage testing of 400/230 V (low voltage) cables

Low voltage paper insulated cables owned and operated by Electricity North West Electricity were mainly purchased to BS 480 Specification for impregnated paper insulated Lead or Lead alloy sheathed electric cables of rated voltages up to and including 33 000 V, first published in the 1930's and since superseded by BS 6480:1988. Appendix A of that specification classifies the Electricity North West Electricity type of distribution system as Class A, defined as a system in which when any phase conductor makes contact with earth it is automatically disconnected. Class A 400/230 V systems require 600/1 000 V rated cables.

Modern polymeric insulated low voltage mains cables are purchased to BS7870 Polymeric insulated, combined neutral/earth (CNE) cables, which does not specify an on site test.

Low voltage cables both paper and polymeric insulated shall be tested after laying using a 500 V Megger (phase to phase and phase to earth), ensuring that the remote ends of cables are safely screened and have danger notices prominently displayed.

**Table 1 – 400/230 V cable DC voltage test**

Cable type	Voltage and duration
400/230 V cables both new and previously in service.	500 V Megger, 1 minute, phase to phase and all phases to earth.

Testing should be carried out on non-commissioned 400/230 V cables before any customers are connected. There is normally no requirement to voltage test a commissioned 400/230 V cable, unless that cable has remained de-energised for a lengthy period of time and hence may have developed a fault or have been damaged. When a commissioned 400/230 V cable is tested, great care must be taken to avoid subjecting the customer's installations and appliances to cable test voltages. Shorting kits applied to the cables should be removed before testing.

In the case of a new or recovered length of cable which is to be jointed into a commissioned live 400/230 V system (for example for a repair) it should be voltage and continuity tested after laying and immediately before jointing. This is to avoid danger to the cable jointer from earth or short circuit currents when connecting the new cable.

## 4.2 Voltage testing of three core cables - sequence of testing

The sequence of voltage testing for all three-core cables is as shown in Diagram 1 and is described as follows:

- (a) First connect all phases to the negative pole of the test set (cable sheaths earthed). For safety, leave the safety screw cap on the positive pole of the test set.
- (b) Next connect phases 1 and 2 together and connect them to the positive pole, with remaining phase 3 connected to the negative pole. Apply equal and opposite polarity voltages to the phases.
- (c) Finally connect phases 2 and 3 together and connect to the negative pole, with phase 1 connected to the positive pole. Apply equal and opposite voltages to the two phases.

During all voltage tests the earth terminal of the test set must remain firmly connected to a substation or switchgear earth conductor (not a painted panel). Cable cores must always be safely discharged to earth using the approved discharge stick before the test arrangement is changed and on completion of testing.

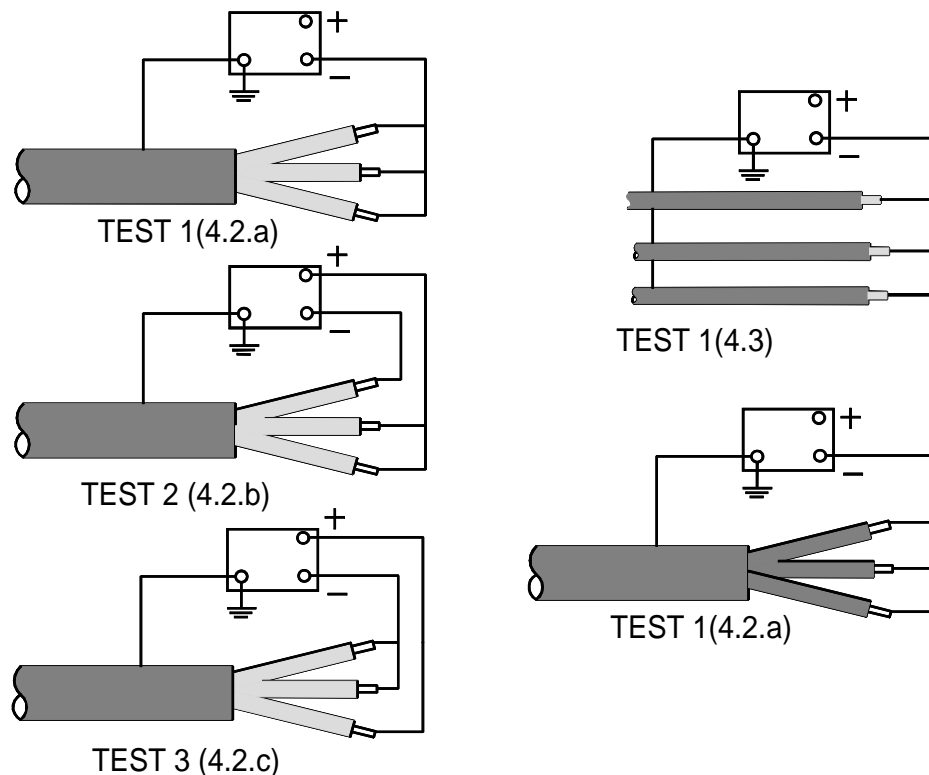

Diagram 1 - Test arrangements and sequences for belted cables (left), single core (right upper) and screened cables (right lower)

## 4.3 Voltage testing of single core and screened cables

Single core and screened cables are tested (negative) phase to earth as shown in Diagram 1. Where three single core cables form a three phase circuit it is customary and time saving to test all three cores simultaneously (providing that the combined leakage current is within the rating of the test set). If the leakage current is excessive, test each core in sequence to determine if one or more cores are defective.



#### 4.4 Test voltage values and durations - 6.6 and 11 kV cables

As in the case of 400/230 V cables, most of the 6.6 and 11 kV paper insulated cables now owned and operated by Electricity North West Electricity were originally purchased to BS 480, which later became BS 6480.

This Lead sheathed type of cable was superseded in the early 1980's by a paper insulated corrugated Aluminium sheathed design to EATS 09-12 Impregnated paper insulated corrugated Aluminium sheath cable, commonly referred to as PICAS cable. BS 6480:1988 specifies commissioning voltage tests for new cables, but EATS 09-12 does not. EATS 09-17 and EATS 09-20 specify single core polymeric insulated cables; these documents do not specify after laying tests. These documents have now been superseded by BS7870.

Table 2A specifies the DC test voltages and duration for newly laid and jointed 6.6 and 11 kV cables and Table 2B for cables previously in service; the voltage values for newly laid and jointed cables correspond with the values given in BS 6480, but with reduced duration. For the present, these values also apply to polymeric insulated cables. Cables intended to be uprated from 6.6 kV to 11 kV are to be tested in accordance with Table 2B.

In order to prevent the over stressing of switchgear, a lower value of test voltage is allowed for cables terminated in non-withdrawable switchgear (oil switches, switch fuses and most ring main units) when the busbars remain live during the DC voltage test. These values appear in the right hand columns of Tables 2A and 2B.

When testing cables through switchgear after installation, circuit breakers should be withdrawn or the switch otherwise isolated, so that the test voltage is only applied to those parts of the switch which cannot readily be disconnected. Switchgear mounted cts may normally remain connected, but vts will need to be isolated.

**Table 2A - DC voltage tests for single and three core, 6.6 and 11 kV cables - newly laid and jointed**

Voltage designation of cable	Cable terminated in withdrawable switchgear, outdoor pole type termination or non withdrawable switchgear with dead busbars			Cable terminated in non withdrawable switchgear with live busbars		
	Between conductors kV	Between conductors and earthed sheath kV*	Duration minutes	Between conductors kV	Between conductors and earthed sheath kV*	Duration minutes
3.8/6.6 kV (paper)	20.0	15.0	5	15.5	7.9	1
6.35/11 kV (paper)	34.0	25.0	5	25.0	13.0	1
6.35/11 kV † (polymeric)	-	10	5	-	10	1

\* In the case of single core cables this is the only test required.

**Table 2B - DC voltage tests for single and three core, 6.6 and 11 kV cables - previously in service, after alteration or repair**

Voltage designation of cable	Cable terminated in withdrawable switchgear, outdoor pole type termination or non withdrawable switchgear with dead busbars			Cable terminated in non withdrawable switchgear with live busbars		
	Between conductors kV	Between conductors and earthed sheath kV*	Duration minutes	Between conductors kV	Between conductors and earthed sheath kV*	Duration minutes
3.8/6.6 kV (paper)	13.5	7.9	5	13.5	7.9	1
6.35/11 kV (paper)	22.5	13.0	5	22.5	13.0	1
6.35/11 kV † (polymeric)	-	10	5	-	10	1

\* - In the case of single core cables this is the only test required.

† - At the time of writing this specification no commercial AC/VLF test equipment is available for testing polymeric cables at this voltage as a direct replacement for the DC pressure test set. However, it is always preferable to test polymeric cables with an alternating voltage.

#### **4.5 Test voltage values and durations - 33 kV cables**

33 kV cables are also specified by BS 480/BS 6480, which covers single and three core mass impregnated non draining (MIND) and HSL types. Oil pressure assisted 33 kV cables are specified by BEBS C4:1966, later superseded by EATS 09-3.

These types of cable may be fitted with insulated oversheaths. If so, they will require commissioning and periodic oversheath voltage testing (see separate section in this Code of Practice).

The voltage test values in Tables 3A and 3B for MIND cables correspond with those in BS 6480.

##### **4.5.1 33kV Polymeric Cables**

All newly laid 33kV polymeric cables must have a test which indicates the level of partial discharge (PD) throughout the circuit. Type test requirements for cables are 5pC whilst joints are limited to 10pC at working voltage ( $U_0$ ). Two tests shall be undertaken, one at  $U_0$  the other to be at  $1.5 U_0$ . It is difficult in the field to measure against the limits stated above due to the level of background noise however, any section of cable or joint showing a discharge activity level greater than 50 pC at  $1.5 U_0$  shall be re-worked. There shall be negligible discharge levels at  $U_0$ .

It should be noted that polymeric cables should be discharge free throughout their service life and these tests are to determine the long term reliability of the joints. The tests can be arranged through EA Technology, Cable Services Section at Capenhurst, Chester (telephone 0151 339 4181).

**Table 3A - DC voltage tests for single and three core 33kV cables - newly laid and jointed**

Voltage designation and type of cable	Cable terminated in withdrawable switchgear, outdoor pole type termination or non withdrawable switchgear with dead busbars		Cable terminated in non withdrawable switchgear with live busbars	
	Between conductors and earthed sheath kV	Duration minutes	Between conductors and earthed sheath kV	Duration minutes
19/33 kV MIND & OIL RO SIN	75	5	40	1
19/33 kV Oil and gas pressure	66	5	40	1
19/33 kV †Polymeric insulated	72	5	40	1

† - At the time of writing this specification no commercial AC/VLF test equipment is available for testing polymeric cables at this voltage as a direct replacement for the DC pressure test set. However, it is always preferable to test polymeric cables with an alternating voltage.

**Table 3B - DC voltage tests for single and three core 33 kV cables - previously in service, after alteration or repair**

Voltage designation and type of cable	Cable terminated in withdrawable switchgear, outdoor pole type termination or non withdrawable switchgear with dead busbars		Cable terminated in non withdrawable switchgear with live busbars	
	Between conductors and earthed sheath kV	Duration minutes	Between conductors and earthed sheath kV	Duration minutes
19/33 kV MIND & OIL ROSIN	40	5	40	1
19/33 kV Oil pressure	40	5	40	1
19/33 kV Polymeric insulated	30	5	30	1

#### 4.6 Test voltage values and duration - 132 kV cables

The present industry standard for 132 kV oil filled cables both single and three core is EATS 09-4, Issue 3, 1991. Type approval tests for these cables are specified in Engineering Recommendation C28/4 1975. Tables 4A and 4B specify the test voltages and duration for these cables. IEC 60840 and IEC 62067 stipulate the levels of test voltages and duration for polymeric cables.

**Warning:** DC tests shall not be applied to 132kV polymeric cables since there is a possibility that high levels of space charge can be built up and retained in the cable. This could be damaging to both the cable and accessories when the cable is made live.

**Table 4A - DC voltage tests for single and three core 132 kV cables - newly laid and jointed, previously in service, after alteration or repair**

Voltage designation and type of cable	Cable terminated in withdrawable switchgear, outdoor pole type termination or non withdrawable switchgear with dead busbars	
	Between conductors and earthed sheath kV	Duration minutes
76/132 kV Oil pressure	80	5

**Table 4B - AC voltage tests for single core polymeric 132 kV cables**

Voltage designation and type of cable	Cable terminated in withdrawable switchgear, outdoor pole type termination or non withdrawable switchgear with dead busbars	
	Between conductors and earthed sheath kV	Duration minutes
76/132 kV polymeric	130	5

#### 4.7 Impulse voltage testing of cables

The voltages specified in this section refer to the maximum impulse voltages, which may be applied to cables during shock discharging for fault location. They are based upon the maximum permissible voltage withstand across the open contacts of a switch disconnector as defined in EATS 41-26 Distribution switchgear for service up to 36 kV, Issue 1, 1991. Ct secondaries must be shorted out and vts isolated. Two testing cases are covered, as follows:

- (a) Cables terminated within withdrawable switchgear, or within non withdrawable switchgear in which the busbars are dead.
- (b) Cables terminated within non withdrawable switchgear with busbars live at normal system voltage.

**Table 5 - Maximum impulse voltages for cables during fault location**

Voltage designation of cable kV	Maximum impulse voltage from capacitor discharge equipment KV	
	Withdrawable switchgear or non withdrawable switchgear with busbars dead	Non withdrawable switchgear, busbars live
BS 6480 EATS 09-3 EATS 09-4 EATS 09-12		
3.8/6.6	16	10
6.35/11	25	15
19/33 MIND	72	42
19/33 pressure assisted	72	42
19/33 XLPE	42*	42*
76/132	280	-

\* On manufacturer's advice.

#### 4.8 Tests on insulated cable oversheaths

Most 132 kV and some 33 kV single core cable circuits have specially bonded sheaths in order to limit the sheath losses and thereby maintain the conductor current rating. All specially bonded cables have insulation over the metal sheath or screen wires of the cable; insulated servings also serve to protect against corrosion of the pressure-retaining sheath. The integrity of this insulation will need to be tested periodically. In addition, sheath voltage limiters (SVL's), that are non-linear Zinc Oxide or Silicon Carbide resistors may be fitted to control sheath voltages during short circuit. The correct operation of these units will also need to be checked. Engineering Recommendation C55/4 1989 provides details of cable bonding systems. CP410 specifies the frequency of sheath testing required.

Generally the removable earth links providing test access to the cable sheath(s) and SVL's will be located in link boxes close to the cable ends, however in multiple cross bonded systems additional link boxes and SVL's may be located along the cable route.

A circuit outage will be required under Electricity North West Electricity Safety Rules, policy and procedures to test both oversheath(s) and SVL's; under no circumstances must any attempt be made to test oversheaths or voltage limiters whilst the circuit is live. Clause 4.6 of Engineering Recommendation C55/4 1989 specifies the following tests:

**Table 6 - Insulated cable oversheath voltage tests from Engineering Recommendation C55/4**

Insulated oversheath DC test on 33 kV and 132 kV cables	
Test voltage DC kV	Duration minutes
10 (when new)	1
5 * (at maintenance)	1

In order to carry out these tests the sheath voltage limiters (SVL's) will need to be disconnected and they should be tested at the same time. The requirements for the maintenance voltage tests on SVL's are specified in Table 6A.

**Table 6A- Voltage tests on SVL's from Engineering Recommendation C55/4 - Silicon Carbide units**

Type of Disc	Test Voltage DC	Current limits at 20°C* mA	
		Site commissioning test	Maintenance test
SVL 8	70	0.5 - 16	0.5 - 50
SVL 16	140	0.5 - 16	0.5 - 50
SVL 28	210	0.5 - 16	0.5 - 50

\* If the temperature is less than 20°C the recorded current must be decreased or increased by 1% for every °C above or below 20°C respectively.

**Table 6B - Voltage tests on SVL's from Engineering Recommendation C55/4 - Zinc Oxide units**

The test voltage shall be adjusted to give a 10 mA test current in each direction and an average shall be taken of the voltages in the two directions. If the ambient temperature is different from 20°C, the recorded voltage must be decreased or increased by 0.1% for every °C above or below 20°C respectively. The corrected voltage values at 20°C must be within the following limits:

Maintenance test	Rated voltage + 17% to + 45%
------------------	------------------------------

#### 4.9 Procedures for cable voltage testing

Cable voltage testing must always be carried out strictly under Electricity North West Electricity Safety Rules, policy and procedures.

HV test sets are heavy, bulky items needing to be treated with care. The HV test leads are especially vulnerable to damage and must not be trapped beneath heavy objects or bent around very small diameters. All test leads must be checked for cleanliness and freedom from damage immediately prior to each occasion of use. Always transport the set with the lid closed (if this is provided), the voltage output socket safety caps in place and with both the set and leads inside the carrying case. Store the unit and all ancillaries in a dry, warm area, free from condensation.

Strict precautions must be observed to ensure safety when voltage testing and this includes wearing HV grade rubber gloves at all times. The best practice is to create a temporary safety enclosure as shown in the sketch with a single defined access point and then use the test set's earthing rod to close the access.

Diagram 2 shows a suitable enclosure for a circuit breaker and similar arrangements can be made for oil switches, fuse switches and ring main units. In the case of vertical isolation, horizontal withdrawal circuit breakers, contact with the cable cores may be made through the spouts using test bushings. In the case of other types of switchgear, test prods should be used. Only approved test bushings/prods are to be used in accordance with EPD306 and they must be inspected for condition prior to each occasion of use. Interlocks allow the test prods to be inserted only when the switch is in the circuit earth position; after insertion the switch earth may be removed.

Tape can be used to define the safety enclosure, but rigid safety barriers of the type used to guard road and footway excavations are much better. DANGER - HIGH VOLTAGE signs should be posted.

Using the earthing rod to close off the safety enclosure ensures that it is the last item to be touched on leaving the area and the first item to be touched on entering it, thereby acting as a permanent reminder of the need to use it.

Position the test set just outside the safety enclosure. Ensure that the set is earthed at all times to a proper earth conductor, not to a painted metal panel. The earth lead must be the first item to connect on setting up and the last item to disconnect on completion of testing.

If the switchgear is sited outdoors then temporary protection against adverse weather conditions will be required.

For 33 kV and especially 132 kV cables, the very high test voltages used require special precautions to avoid flashover. Sharp edged metalwork will require shielding by temporary additional insulation. Adhesive backed Butyl Rubber sheet is useful for this purpose.

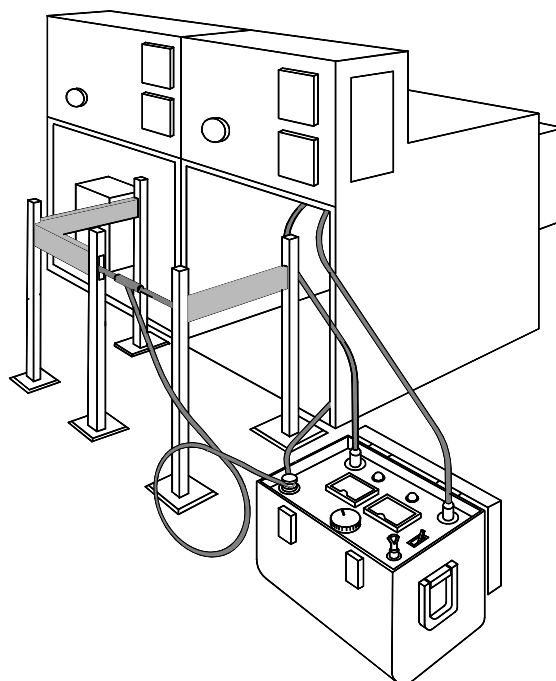

*Diagram 2 - Temporary enclosure for voltage testing*

When the safety enclosure is in place, testing may proceed. The test set output voltage should be built up from zero smoothly and progressively to avoid surges and high input currents. DC test sets provide equal and opposite positive and negative outputs and should be connected as described in section 5.2. Once the voltage is above 75% of the test value the rate of rise should not exceed 2% of the test value per second. Hold the required voltage for the prescribed period of time then reduce it to zero in a similar manner. In the case of very long cables the charging current may limit the rate at which the voltage can be raised. Some test sets are fitted with an automatic feature to control the rate of voltage rise. The test period begins only when the correct voltage is applied and the voltage must be fully maintained until the end of the test period. To meet the requirements of BS 923:1990 Guide on high voltage test techniques, the applied voltage must be maintained within  $\pm 1\%$  for tests up to 1 minute duration and within  $\pm 3\%$  for tests lasting longer than 1 minute.

When testing cables using DC, the phase to phase and phase to earth capacitances can store considerable and very dangerous amounts of energy. The energised phases must be discharged to earth through the earth (resistor) rod, never directly. Polymeric insulated cables require special care, because the dielectric is an almost perfect insulator and can rebuild a significant voltage over time, even after the conductor has been fully discharged to earth. A polymeric insulated cable conductor must always be earthed immediately before touching it. It should be noted that DC testing must never be used on 132kV Polymeric cables.

When testing older cables, some leakage current can be expected. It is difficult to give guidance on a tolerable level of leakage because this will vary with cable length, however excessive leakage is a sure indication of a cable and/or cable joints nearing the end of their service life. Outdoor (pole) terminations can have a significant leakage current, especially if the insulation surfaces are polluted and/or the weather is damp. Do not attempt to voltage test cables which remain connected to significant lengths of overhead line, because the leakage current over the insulators will mask the leakage current through the cable insulation.

When testing older paper insulated cables and/or cables ending in outdoor terminations, ensure that the leakage current is compatible with the continuous or short term rating of the test set. These ratings will be specified in the set's user manual and may be marked on the control panel as well. It should not be possible to exceed the short term current rating as the set should trip out; however if the leakage current is greater than the continuous rating but within the short term rating, it will be necessary to allow cooling down periods between tests.

## 5. VOLTAGE TESTING OF SWITCHGEAR

Depending upon the form of construction, test voltages should be applied as follows:

- (a) Between phases and between phases and earth (on non-phase segregated switchgear). The sequence of testing should be the same as that specified for three core cables in section 4.2 of this Code.
- (b) Between phases and earth only (on phase segregated switchgear).

The tables in this section specify both AC 50 Hz and DC test voltages. In general AC testing is preferred, because AC stresses the insulation in the same manner as it is stressed in service. However, DC testing may be used if an AC test set is not available. Whether AC or DC testing is employed, the leakage current for switchgear should be extremely small, less than 1 mA and the cause of any significant leakage must be investigated and rectified. All the internal parts of the switchgear, especially the support and through bushings and the densified wood linkages, must be completely free from moisture (including condensation) before testing starts and oil switchgear must be filled to the correct level with clean and tested oil.



In addition to an overall test of the equipment with the contacts closed, the equipment shall also be tested with the main contacts open and each side earthed alternately. This is to test the voltage withstand of the contact insulation gap.

It is also necessary to voltage test the wiring, secondary contacts and other auxiliary components of switchgear, together with the motor circuits, if the equipment is power operated.

Tables 7A and 7B specify voltage test values for these items; those for electric motors are taken from BS 5000:Part 10:1988 General-purpose induction motors (related to IEC72). Take care however not to subject the secondary wiring of current transformers and other protection wiring to test voltages, particularly if the protection relays are of the electronic type.

Where the switchgear includes current transformers it is appropriate to include them in the voltage tests including DC tests (unless the manufacturer's manual prohibits the application of DC). However it is necessary to disconnect voltage transformers during phase to phase testing. This should be done by removing the voltage transformer fuses on the high voltage side in sequence, so that all the voltage transformer fuse carriers are subjected to the test voltage in turn.

### 5.1 New switchgear

New switchgear will be subjected to routine testing at the manufacturer's works in accordance with the relevant specification, which is BS 5227:1984 Specification for metal enclosed switchgear and control gear for rated voltages above 1 kV up to and including 72 kV (related to IEC 298). This standard also specifies the after erection voltage test values, which have been used to construct Table 7A.

**Table 7A Test voltages for new switchgear after erection**

Item	System rated voltage kV	Test voltage	
		AC test voltage kV	DC test voltage kV
Main circuit of switchgear other than neutral earthing switchgear	0.66	2.0	2.0
	6.6	20.0	19.5
	11.0	28.0	32.5
	33.0	70.0	80.0
	132.0	275.0	80.0
Main circuit of neutral earthing switchgear	3.81	10.0	-
	6.35	15.0	-
	19.1	40.0	-
Auxiliary circuits	-	2.0	-
Operating motors	In accordance with BS 5000 Part 10		
Test duration one minute in all cases			

### 5.2 Previously in service switchgear

Table 7B gives the appropriate voltage test values and durations for switchgear previously in service in which any part of the insulation has been altered, modified, refurbished or repaired. These are not based upon BS 5227, but nevertheless they have been found to give satisfactory results over a long period of time.

In a similar manner to the testing of cables, reduced test voltages are applicable to previously in service switchgear to which live HV cables are connected, or where another part of the switchgear, for example the busbars, remains live during testing. In these cases DC testing should be used.

Note that it is unnecessary to perform a full voltage test on switchgear that has been subjected only to normal planned routine maintenance; in these circumstances a 5 000 V MEGGER test is sufficient. Where switchgear remains connected to cable/overhead line sections the principles of cable testing detailed in 4.9 will apply.

In the case that a full voltage test is impractical, the following procedure shall be followed, either locally or at a remote point to the equipment under test:

- (a) Megger test 5 000 V between all phases and earth.
- (b) Operate switchgear or plant into the closed or service position and repeat (a) to confirm that unearthed transformers are connected.

The above procedure is intended to demonstrate to engineers that test voltage is being applied and that there is no intervening open switch. However a full voltage test should be carried out if a major insulation component, for example a through bushing or a phase barrier, has been replaced.

**Table 7B Test voltages for previously in service switchgear after alteration or repair**

Item	System rated voltage kV	Test voltage	
		AC test voltage kV	DC test voltage (also to be used when the cable or busbar is live) kV
Main circuit of switchgear other than neutral earthing switchgear	0.66	2.0	1.0
	6.6	11.4	7.9
	11.0	18.0	13.0
	33.0	51.0	40.0
	132.0	200.0	80.0
Main circuit of neutral earthing switchgear	3.81	7.5	-
	6.35	11.0	-
	19.1	30.0	-
Auxiliary circuits	-	2.0	-
Operating motors	In accordance with BS 5000 Part 10		
Test duration one minute in all cases			

### 5.3 Procedures for switchgear voltage testing

If the equipment is to be tested on site, then the procedures should be the same as those described for cable testing in section 4.9 of this Code of Practice. The procedures should include the erection of a temporary safety enclosure, temporary weather protection if required, extra insulation and the issue of a Sanction for Test. In general new switchgear is best tested after erection and before cabling up. In the case of existing vts tested on site, including those mounted externally on switchgear, special precautions will need to be taken. This will include the construction of a safety zone with barriers and strict observance of safety clearances.

Vertical isolation, horizontal withdrawal circuit breakers should be tested with the circuit breaker in the service position if possible, although if this is operationally inconvenient the breaker and the housing may be tested separately. If the breaker is withdrawn, connections for voltage testing can usually be made through the bushing spouts, using insulated test connectors. For switch fuses, circuit (fault making/load breaking) switches and ring main units, voltage testing should also be carried out before the connection of main cables, thereby allowing test voltages to be applied via the cable box bushing end connections.

Extreme care needs to be taken when testing 33 kV and 132 kV plant on site, due to the very high voltages employed and the consequent possibility of flashover over long distances, especially in damp weather.

Previously in service switchgear that is already cabled presents more of a problem, because the test prods connect only to the cable ends, not the internal busbars. In these cases consideration will need to be given to testing from an adjacent substation via the cable connection. Alternatively it may be possible to remove a distribution transformer lid, temporarily remove the HV winding leads and test via the transformer cable or busbar connection. This work will need to be carried out under Electricity North West Electricity Safety Rules, policy and procedures.

In the case of switchgear which is voltage tested in workshops, a proper metal mesh enclosed test cell equipped with flashing red warning lamps, automatically controlled earthing and an access door or doors fully interlocked with the test set must always be used. The person carrying out this work must be accompanied.

## 6. VOLTAGE TESTING OF VOLTAGE AND CURRENT TRANSFORMERS

This section describes procedures for testing of voltage transformers and current transformers where they are tested separately from switchgear or other plant.

The relevant specifications are as follows:

- (a) BS 3941:1975 Specification for voltage transformers (related to IEC 186, IEC 358).
- (b) BS 3938:1973(1982) Specification for current transformers (related to IEC 185).

Both of these specifications give routine (works) and on site voltage test values, which are similar to those for switchgear. All voltage tests apply to normal operational conditions with the oil filling present (if required) and all covers in place.

Testing of current transformers and voltage transformers in workshops when separated from switchgear must be carried out only in test enclosures having the same safety facilities as required for the testing of switchgear.

## 6.1 Testing of voltage transformers

The test voltages are specified in Table 8A and 8B. They are to be applied between the high voltage terminals of the voltage transformer (connected together) and earth; the frame, tank and low voltage winding terminals shall also be connected to earth. If the high voltage winding is star connected with the star point normally earthed, it is to be disconnected from earth. Whilst disconnected from earth the high voltage winding to earth resistance shall be measured at 1 000 V DC.

In voltage transformers where the high voltage winding is divided into sections, each section should be tested to be capable of withstanding 2 kV AC between itself and all other windings connected together and to frame and earth. If the voltage transformer is suspected of being faulty it will be necessary to carry out injection testing from the low voltage side as described in section 6.2 of this Code of Practice.

**Table 8A Test voltages for current transformers and voltage transformers after erection**

Item	System Rated voltage kV	Test voltage kV	
		AC test voltage kV	DC test voltage kV
Main circuit of switchgear other than neutral earthing switchgear	0.66	2.0	2.0
	6.6	20.0	19.5
	11.0	28.0	32.5
	33.0	70.0	80.0
	132.0	275.0	80.0
Main circuit of neutral earthing switchgear	3.81	10.0	-
	6.35	15.0	-
	19.1	40.0	-
Test duration one minute in all cases			

**Table 8B Test voltages for previously in service current transformers and voltage transformers**

Item	System rated voltage kV	Test voltage kV	
		AC test voltage kV	DC test voltage kV
Main circuit of switchgear other than neutral earthing switchgear	0.66	2.0	1.0
	6.6	11.4	7.9
	11.0	18.0	13.0
	33.0	51.0	40.0
	132.0	200.0	80.0
Main circuit of neutral earthing switchgear	3.81	7.5	-
	6.35	11.0	-
	19.1	30.0	-
Test duration one minute in all cases			

## 6.2 Testing of voltage transformers by induced voltage

This type of testing is employed as a diagnostic tool for suspect voltage transformers. Two procedures are described, the first applies if the low voltage winding star point is available and the second if it is not. In both tests the high voltage winding star point, if available, must be earthed.

### 6.2.1 Voltage transformer testing by induced voltage – low voltage star point available

With the test arrangement as shown below, proceed as follows:

- (a) Using a Variac and series resistor, inject the first phase to neutral connection.

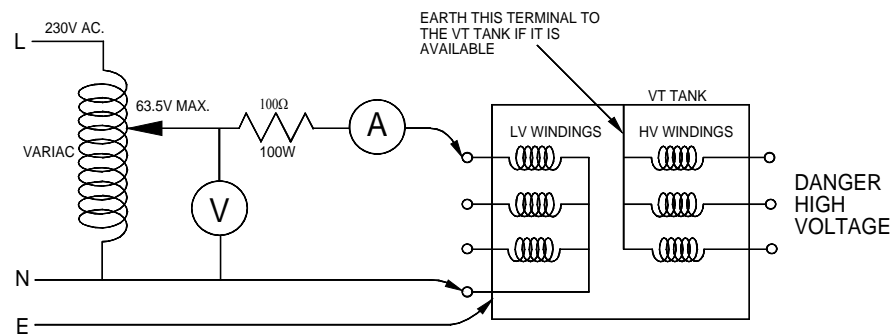

Diagram 3 - Test connections for voltage transformer testing if the low voltage winding star point is available

- (b) Steadily increase the applied voltage from zero but do not exceed a maximum of 63.5 V. When 63.5 V is attained, measure and record the injected current then switch off.

- (c) Repeat the procedure for phases 2 and 3. If the injected current on any phase exceeds the lowest current on either of the other phases by more than 50%, or exceeds 300mA, the voltage transformer is faulty and must be repaired.

### 6.2.2 Voltage transformer testing by induced voltage – low voltage star point not available

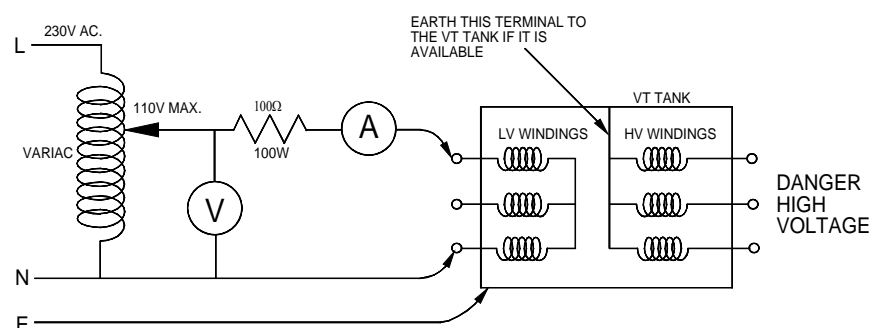

Diagram 4 - Test connections for voltage transformer if the low voltage winding star point is not available

With the test arrangement as shown, proceed as follows:

- (a) Using a Variac and series resistor, inject the first phase to phase connection.
- (b) Steadily increase the voltage from zero but do not exceed a maximum of 110 V. When 110 V is attained, measure and record the injected current then switch off.
- (c) Repeat the procedure for phases 2 and 3. If the injected current on any phase exceeds the lowest current on either of the other phases by more than 50%, or exceeds 200mA, the voltage transformer is faulty and must be repaired.

## 7. VOLTAGE TESTING OF TRANSFORMERS

Voltage tests at the manufacturer's works on new or repaired transformers are normally to BS 171:1970 Specification for Power Transformers (as amended) or EATS 35-1 Distribution transformers (from 16 kVA to 1 000 kVA).

On site tests are specified by Table 9 for new and refurbished or previously in service transformers. The DC voltages they specify are 75% of the works test value for new transformers and 75% of the new-on-site value for repaired transformers. The voltage values for repaired transformers on site are also applicable to all BS 171 transformers that are being re-commissioned after modification. Test voltage shall be applied between the HV windings connected together and the secondary windings and tank, which shall be connected together and to earth. In the case of autotransformers, the test voltage should be based upon the system highest voltage to which any of the windings of the transformer will be connected.

Where it is not reasonably practical to apply the specified test voltage, a 1 000 V Megger test applied for one minute may be substituted. This concession will generally apply to pole transformers. In addition, where the test voltage cannot reasonably be made available on site, a test of 30 kV DC for one minute may be applied.

**Table 9 Test voltages for oil filled transformers**

Voltage of system kV	New transformer on site		Repaired transformer on site	
	AC test kV	DC test kV	AC test kV	DC test kV
6.6	15	21	11	16
11	21	30	16	22
33	53	74	40	56
132 (non uniform insulation)	34	-	25	-
132 1 phase (uniform insulation)	206	-	154	-
25 – 1 phase	71	-	53	-

### 7.2 Procedures for transformer voltage testing

If the equipment is to be tested on site, then the procedures should be the same as those described for cable testing in section 4.9 of the Code. This will include the erection of a temporary safety enclosure, temporary weather protection if required, extra insulation and the issue of a Sanction for Test. The HV cable boxes of transformers, especially distribution transformers, can be small in comparison with the clearances required for the test voltages. This means that in most cases additional temporary insulation will be required. Flexible Butyl Rubber sheet and/or rigid Paxolin sheet is convenient for this purpose.

## 8. STANDARDS REFERENCED

- 8.1 BS 923:1980/90 Guide on high voltage test techniques.
- 8.2 BS 6480:1988 Specification for impregnated paper insulated lead or lead alloy sheathed electric cables of rated voltages up to and including 33 000 V (related to IEC 55.1 and 55.2).
- 8.3 BS 5000:Part 10:1988 General purpose induction motors (related to IEC72).
- 8.4 BS 5227:1984 Specification for metal enclosed switchgear and control gear for rated voltages above 1 kV up to and including 72 kV.
- 8.5 BS 3941:1975 Specification for voltage transformers (related to IEC 186, IEC 358).
- 8.6 BS 3938:1973(1982) Specification for current transformers (related to IEC 185).
- 8.7 BS 171:1970 Specification for Power Transformers (as amended).
- 8.8 EATS 09-2 The installation of 33 kV and higher voltage power cables and associated auxiliary cables.
- 8.9 EATS 09-3 33 kV impregnated paper insulated oil filled and gas pressure type power cable systems, Issue 2, 1982.
- 8.10 EATS 09-9 Polymeric insulated, combined neutral/earth (CNE) cables with solid aluminium phase conductors and concentric aluminium wire waveform neutral/earth conductor.
- 8.11 EATS 41-26 Distribution switchgear for service up to 36 kV, Issue 1, 1991.
- 8.12 EATS 35-1 Distribution transformers (from 16 kVA to 1 000 kVA).
- 8.13 BS7870 - LV and MV polymeric insulated cables

## 9. KEYWORDS

Testing; VT; Switchgear; Voltage; Safety; CT; Insulation