

# Code of Practice 410

Issue 7      January 2024

## Mains Practice up to and including 132kV. Underground Cable Systems



## Amendment Summary

ISSUE NO. DATE	DESCRIPTION
<p><b>Issue 6</b> <b>August 2024</b></p>	<p>Format updated to combine all the Chapters into one combined document for ease of navigation on electronic devices.</p> <p><u><a href="#">EPD410 (Inspection and Maintenance Policy for Company Owned Cable Bridges) has been archived and the information from it incorporated into Chapter5 of this CP.</a></u></p> <p>Prepared by: P. Howell Approved by: Policy Approval Panel and signed on its behalf by Paul Turner Chairperson</p>
<p><b>Issue 7</b> <b>January 2024</b></p>	<p><u><a href="#">Chapter 6 added to cover policy and guidance on Shallow Cables</a></u> <u><a href="#">Correction of non-inclusive text</a></u></p> <p>Prepared by: P. Howell Approved by: Policy Approval Panel and signed on its behalf by Paul Turner Chairperson</p>

## Contents

Chapter 1 – Power Cables Approved Types	5
1 Definitions	5
2 Approved Cables	5
3 Approval of Cables	5
4 Ordering Power Cables for General Use	5
5 Continued use of Previously Installed Cables (Historic Designs)	5
6 Approved Low Voltage Cables	6
7 Approved Cables for 11kV Systems	8
8 Approved Cables for 33kV Systems	9
9 Documents Referenced	9
Chapter 2 – Protecting Cable Installations from the Effects of Contaminated Land	10
1 Definitions	10
2 Requirements	10
3 Documents Referenced	14
Chapter 3 – General Installation Practice for Cables up to 132kV	17
1 Definitions	17
2 Preparatory Work	17
3 Excavation of Trenches	18
4 Timbering of Excavations	22
5 Cables Laid in Trenches and Ducts	24
6 Bedding, Blinding and Backfilling	28
7 Equipment for Cable Laying	30
8 Method of Pulling in Cables	31
9 Additional Work	35
10 Documents Referenced	39
Chapter 4 – Cable Drums	40
1 Definitions	40
2 Storage of Cable Drums	40
3 Handling and Transport of Cable Drums	41
4 Transporting Cable Drums	43
5 Documents Referenced	44

Chapter 5 – Cable Bridges and Similar Structures	47
1 Definitions	47
2 Preparatory Work	47
3 Inspection and Maintenance Policy for Company Owned Cable Bridges	55
4 Documents Referenced	56
Appendix A– Investigation of Subsoil	58
Appendix B– Design of Simple Plain Concrete Foundations	62
Appendix C – Application of Structural Loads	64
Chapter 6 – Shallow Cables	74
1 Definitions	74
2 Introduction	74
3 Process	75
4 Additional Measures	76
5 Example Risk Assessment Layout	81
6 Documents Referenced	82

All Rights Reserved

The copyright of this document, which contains information of a proprietary nature, is vested in Electricity North West Limited. The contents of this document may not be used for purposes other than that for which it has been supplied and may not be reproduced, either wholly or in part, in any way whatsoever. It may not be used by, or its contents divulged to, any other person whatsoever without the prior written permission of Electricity North West Limited.

## Chapter 1 – Power Cables Approved Types

This chapter covers the Approved types of power cables for general use within Electricity North West Limited.

### 1 Definitions

ENWL	Electricity North West Limited
CNE	Concentric Neutral Earth
SCNE	Split Concentric Neutral & Earth
LSOH	Low Smoke, Zero Halogen
XLPE	Cross Linked Polyethylene

### 2 Approved Cables

The following tables list the current Approved power cables used by ENWL for general use, including their Commodity Codes (where applicable).

- [Section 6](#) lists the approved cables used by ENWL on LV circuits.
- [Section 7](#) lists the approved cables used by ENWL on 11 kV circuits.
- [Section 8](#) lists the approved cables used by ENWL on 33 kV circuits.

### 3 Approval of Cables

For all polymeric cables approval is granted for the cable to be manufactured at one site location. Approval does not mean 'blanket' approval for all the cable types and site locations that a manufacturer may have.

Details of current approved manufacturers and location by cable type can be found in ES281 – Part 2&5

### 4 Ordering Power Cables for General Use

List the appropriate cable description as detailed in Sections 6 to 8 of this chapter on all purchasing requisitions

If a requisition is to include cables not listed in Sections 6 to 8 of this chapter an Engineering Report specifying in detail the reasons why the Approved type of cable is not considered suitable for use on ENWL systems must accompany any requisition.

Where alternative conductor materials are allowable, order the most economical type at the time of purchase.

### 5 Continued use of Previously Installed Cables (Historic Designs)

Previously installed cables are approved for continued use depending on their being in a safe condition.

## 6 Approved Low Voltage Cables

ITEM	ORDERING SPECIFICATION	PHASE CONDUCTOR MATERIAL	PHASE CONDUCTOR SIZE (MM <sup>2</sup> )	COMMODITY CODE	DESCRIPTION
1	<u>3-core polymeric insulated waveform cable:</u> As per ENWL specification ES400C11	Solid Sector shaped Aluminium	95	<b>003697</b>	95mm 3c Waveform Cu N/E Cable
			185	<b>003700</b>	185mm 3c Waveform Cu N/E Cable
			300	<b>003727</b>	300mm 3c Waveform Cu N/E Cable
2	<u>3-core polymeric insulated waveform cable: with LSOH sheath for increased fire properties:</u> As per ENWL specification ES400C11	Solid Sector shaped Aluminium	95	<b>329253</b>	95mm 3c Waveform Cu N/E LSOH Cable
			185	<b>955255</b>	185mm 3c Waveform Cu N/E LSOH Cable
			300	<b>955256</b>	300mm 3c Waveform Cu N/E LSOH Cable
3	<u>4-core polymeric insulated waveform cable:</u> As per ENWL specification ES400C11	Solid Sector shaped Aluminium	95	<b>003735</b>	95mm 4c Waveform Cu Earth Cable
			185	<b>000701</b>	18mm 4c Waveform Cu Earth Cable
			300	<b>003759</b>	300mm 4c Waveform Cu Earth Cable
4	<u>4-core polymeric insulated waveform cable with LSOH sheath for increased fire properties:</u> As per ENWL specification ES400C11	Solid Sector shaped Aluminium	95	<b>003760</b>	95mm 4c Waveform Cu Earth LSOH Cable
			185	<b>003761</b>	18mm 4c Waveform Cu Earth LSOH Cable
			300	<b>003762</b>	300mm 4c Waveform Cu Earth LSOH Cable
5	<u>Single phase (SCNE) service cables:</u> As per ENWL specification ES400C8	Stranded Copper	4	<b>000213</b>	4 Cu 1c SCNE LV Service Cable
		Solid Aluminium	25	<b>000280</b>	25 SAC 1c SCNE LV Service Cable
			35	<b>000299</b>	35 SAC 1c SCNE LV Service Cable
6	<u>Single phase (SCNE) service cables with LSOH sheath for increased fire properties</u> As per ENWL specification ES400C8	Stranded Copper	4	<b>000364</b>	4 Cu 1c SCNE LV LSOH Service Cable
		Solid Aluminium	25	<b>000367</b>	25 SAC 1c SCNE LV LSOH Service Cable
			35	<b>000368</b>	35 SAC 1c SCNE LV LSOH Service Cable
7	<u>Single phase (CNE) service cables:</u> As per ENWL specification ES400C8	Stranded Copper	4	<b>000108</b>	4CU 1c CNE LV Service Cable
		Solid Aluminium	25	<b>000167</b>	25 SAC 1c CNE LV Service Cable
			35	<b>000175</b>	35 SAC 1c CNE LV Service Cable

8	<u>Single phase (CNE) service cables with LSOH sheaths for increased fire properties</u> As per ENWL specification ES400C8	Stranded Copper	4	<b>TBA</b>	4CU 1c CNE LV LSOH Service Cable
		Solid Aluminium	25	<b>000367</b>	25 SAC 1c CNE LV LSOH Service Cable
			35	<b>000365</b>	35 SAC 1c CNE LV LSOH Service Cable
9	<u>Three phase (SCNE) service cables:</u> As per ENWL specification ES400C8	Solid Aluminium	25	<b>002127</b>	25 SAC 3c SCNE LV Service Cable
10	<u>Three phase (SCNE) service cables with LSOH sheaths for increased fire properties</u> As per ENWL specification ES400C8	Solid Aluminium	25	<b>00371</b>	25 SAC 3c SCNE LV LSOH Service Cable
11	<u>Three phase (CNE) service cables:</u> As per ENWL specification ES400C8	Solid Aluminium	25	<b>002119</b>	25 SAC 3c CNE LV Service Cable
12	<u>Three phase (CNE) service cables with LSOH sheath for increased fire properties</u> As per ENWL specification ES400C8	Solid Aluminium	25	<b>TBA</b>	25 SAC 3c CNE LV LSOH Service Cable

## 7 Approved Cables for 11kV Systems

ITEM NO	ORDERING SPECIFICATION	PHASE CONDUCTOR MATERIAL	PHASE CONDUCTOR SIZE (MM <sup>2</sup> )	COMMODITY CODE	DESCRIPTION
1	<u>Single core polymeric insulated cables laid up in triplex formation</u> As per ENWL Specification ES400 C9	Solid Circular Aluminium	95	<b>004691</b>	Cable 95mm <sup>2</sup> AL triplex XLPE 11kV
			185	<b>004692</b>	Cable 185mm <sup>2</sup> AL triplex XLPE 11kV
			300	<b>004693</b>	Cable 300mm <sup>2</sup> AL triplex XLPE 11kV
2	<u>Single core polymeric insulated cables laid up in triplex formation with LSOH sheaths for increased fire properties</u> As per ENWL Specification ES400 C9	Solid Circular Aluminium	95	<b>995183</b>	Cable 95mm <sup>2</sup> AL triplex XLPE 11kV LSOH
			185	<b>995184</b>	Cable 185mm <sup>2</sup> AL triplex XLPE 11kV LSOH
			300	<b>995185</b>	Cable 300mm <sup>2</sup> AL triplex XLPE 11kV LSOH
3	<u>Single core polymeric insulated cables:</u> As per ENWL Specification ES400 C9	Stranded Circular Copper	400	<b>004701</b>	Cable 400mm <sup>2</sup> XLPE 1c CU 11kV
			630	<b>004703</b>	Cable 630mm <sup>2</sup> XLPE 1c CU 11kV
		Stranded Circular Aluminium	400	<b>005702</b>	Cable 400mm <sup>2</sup> XLPE 1c AL 11kV
4	<u>Single core polymeric insulated cables with LSOH sheath for increased fire properties</u> As per ENWL Specification ES400 C9	Stranded Circular Copper	400	<b>004761</b>	Cable 400mm <sup>2</sup> XLPE 1c CU 11kV LSOH
5	<u>Single core polymeric insulated cables laid up in triplex formation</u> As per ENWL Specification ES400 C9	Stranded Circular Copper	400	<b>TBA</b>	Cable 400mm <sup>2</sup> CU triplex XLPE 11kV
		Stranded Circular Aluminium	400	<b>005702</b>	Cable 400mm <sup>2</sup> AL triplex XLPE 11kV



## 8 Approved Cables for 33kV Systems

ITEM NO	ORDERING SPECIFICATION	PHASE CONDUCTOR MATERIAL	SIZE (MM <sup>2</sup> )	COMMODITY CODE	DESCRIPTION
1	<u>Single core polymeric insulated cables</u> <u>Single cores or laid up in a triplex formation:</u> Cables to be in accordance with ENWL Specification 400 C10.	Stranded Circular Copper	185	<b>046100</b>	<b>Single core:</b> Cable 33KV XLPE Cu 1c 185mm <sup>2</sup>
			240	<b>046101</b>	Cable 33KV XLPE Cu 1c 240mm <sup>2</sup>
			300	<b>046102</b>	Cable 33KV XLPE Cu 1c 300mm <sup>2</sup>
			400	<b>046103</b>	Cable 33KV XLPE Cu 1c 400mm <sup>2</sup>
			500	<b>046104</b>	Cable 33KV XLPE Cu 1c 500mm <sup>2</sup>
			630	<b>046106</b>	Cable 33KV XLPE Cu 1c 630mm <sup>2</sup>
			185	<b>004696</b>	<b>Triplicated single core:</b> Cable 33KV XLPE Cu 3x 1c 185mm <sup>2</sup>
			240	<b>004696</b>	Cable 33KV XLPE Cu 3x 1c 240mm <sup>2</sup>
			300	<b>004697</b>	Cable 33KV XLPE Cu 3x 1c 300mm <sup>2</sup>
			400	<b>004698</b>	Cable 33KV XLPE Cu 3x 1c 400mm <sup>2</sup>
500	<b>004700</b>	Cable 33KV XLPE Cu 3x 1c 500mm <sup>2</sup>			
2	<u>Single core polymeric insulated cables</u> <u>Single cores or laid up in a triplex formation:</u> Cables to be in accordance with ENWL Specification 400 C10.	Stranded Circular Aluminium	300	<b>004699</b>	<b>Single core:</b> Cable 33KV XLPE AL 1c 300mm <sup>2</sup>
			400	<b>331388</b>	Cable 33KV XLPE AL 1c 400mm <sup>2</sup>
			500	<b>046203</b>	Cable 33KV XLPE Al 1c 500mm <sup>2</sup>
			630	<b>331389</b>	Cable 33KV XLPE Al 1c 630mm <sup>2</sup>
			800	<b>331390</b>	Cable 33KV XLPE Al 1c 800mm <sup>2</sup>
			1000	<b>331391</b>	Cable 33KV XLPE Al 1c 1000mm <sup>2</sup>
			300	<b>046200</b>	<b>Triplicated single core:</b> Cable 33KV XLPE Al 3x 1c 300mm <sup>2</sup>
			400	<b>046201</b>	Cable 33KV XLPE Al 3x 1c 400mm <sup>2</sup>
			500	<b>046202</b>	Cable 33KV XLPE Al 3x 1c 500mm <sup>2</sup>

## 9 Documents Referenced

DOCUMENTS REFERENCED	
<b>ENWL Specification ES400 C8</b>	Specification for LV service cables.
<b>ENWL Specification ES400 C11</b>	Specification for LV distribution cables.
<b>ENWL Specification ES400 C9</b>	Specification for 11 kV distribution cables.
<b>ENWL Specification ES400 C10</b>	Specification for 11 kV distribution cables.
<b>ENWL Specification ES 281</b>	Company Specific Appendices to ENA ER G81 : Part2/5 Approved Equipment
<b>BS 7870 Series</b>	LV and MV Polymeric Insulated Cables for Use by Distribution and Generation Utilities

## Chapter 2 – Protecting Cable Installations from the Effects of Contaminated Land

The requirements of this Chapter are applicable to all cable installations in contaminated land.

The reliability of cable systems installed in contaminated land shall be no less than that of those installed elsewhere. The contaminants on such sites, however, may have a detrimental effect on the materials from which the cables and accessories are manufactured. Where this is the case, precautions as described in this Chapter shall be taken to ensure the reliability of the installation.

No previous guidance has been issued dealing with the effect on cables and accessories of substances found in contaminated land. Both CIRIA and ERA have reported on research undertaken on this topic and their findings contain advice relevant to both materials and reliability as well as health, safety and environmental issues.

The requirements of this Chapter are based on the findings of these two reports, details of which will be found listed in [Section 3](#) (Documents Referenced).

### 1 Definitions

<b>Contaminated Land</b>	Shall mean land containing substances that, when present in sufficient quantity or concentrations, are likely to cause harm directly or indirectly to installed apparatus, people or protected species, or pollution of surface water or groundwater.
<b>CIRIA</b>	Construction Industry Research and Information Association <a href="https://www.ciria.org/">https://www.ciria.org/</a>
<b>ENWL</b>	Electricity North West Limited
<b>ERA</b>	Electrical Research Association (ERA Technology Ltd) – now trading as RINA Tech UK Limited <a href="https://www.rina.org/">https://www.rina.org/</a>

### 2 Requirements

#### 2.1 General Description of Problem

Wherever cable installation is proposed it is necessary to consider the suitability of the environment, as follows:

##### 2.1.1 Greenfield Sites

Conditions on such sites may be apparently benign, but the following possibilities should not be overlooked:

- The residue of early or pre-industrial processes may be present but well disguised by later agricultural activity.
- Slurry leakage and chemical run-off from current agricultural processes may create conditions that present a hazard to the installation.

### 2.1.2 Land Under Highways and Similar Situations

Liquid and gaseous residues that are detrimental to the cable installation may be found leaking from various underground services, such as:

- Sewerage.
- Liquid residues from corroded metal gas pipes.
- Cable fluid.
- Methane gas.

### 2.1.3 Brownfield Sites

Sites formerly used for many industrial and commercial activities are likely to contain contaminants in significant amounts. The local Planning Authority has a duty to maintain details of such sites, and the Department of Environment has published a list of Industry Site Profiles showing the hazards presented by the former activities at the location. To obtain a copy of any of the Profiles, refer to [Section 3](#) (Documents Referenced). These provide developers; local authorities and anyone else interested in contaminated land, with information on the processes, materials and wastes associated with individual industries. They also provide information on the contamination, which might be associated with specific industries, factors that affect the likely presence of contamination, the effect of mobility of contaminants and guidance on potential contaminants. They are not definitive studies, but they introduce some of the technical considerations that need to be borne in mind at the start of an investigation for possible contamination.

## 2.2 Effects Likely to Occur

The effects that are likely to occur are well summarised in the ERA Report, and reference to this is recommended for detailed information. In summary, however, the major hazards to cable reliability are likely to arise from:

- Degradation of the cable oversheath, sheath or armouring.
- Swelling of plastic materials.
- Ignition of combustible material in the soil.
- Premature ageing of insulation due to high ambient temperature.
- Mechanical damage.
- Transport of contaminants along the cable route.
- Methane released from old mine workings.

## 2.3 Performance of Cables and Accessories in Contaminated Land

### 2.3.1 Cables

The current cable designs used in the Company incorporate an oversheath of polymeric material, applied according to the requirements of BS 7655. It is notable that this Standard does not contain a test for chemical compatibility. The absence of any such requirement means that the specification of a polymeric oversheath for use in contaminated land is a matter of agreement between the Supplier and the ENWL Circuits Policy Manager.

### 2.3.2 Accessories

Current designs of cable joints are encased in either an elastomer, plastic or glass-fibre casing. The performance of these materials in terms of resistance to contaminants is about equivalent to polymeric oversheath materials, but they are not tested in this regard. The use of the materials in contaminated land, therefore, is also a matter for agreement between the Supplier and the ENWL Circuits Policy Manager.

## 2.4 Actions Required

### 2.4.1 Desk Top Study

The risk to the cable system shall be investigated having regard to the hazards described in [Section 2.1](#). The level of formality applied to this process will vary according to the perceived risk at the outset.

If the proposed installation is on a brownfield site under redevelopment a formal investigation shall always be made. The Developer has a duty to provide a copy of the Site Investigation Report, giving comprehensive details of any contaminants. Otherwise, if the site is not a redevelopment area, then the Planning Authority and the Environment Agency shall be consulted. It is possible, however, that the information from these sources may not be comprehensive.

The Desk Top Study will identify:

- The present and past use of the land.
- The potential contaminants arising from them.
- The manner in which they may have migrated.
- What sources of further information may be available?
- Will the contamination cause a problem for cables and accessories
- Whether the problem can be avoided by re-routing the cable.

### 2.4.2 Site Investigation

Where a significant hazard that cannot be avoided is identified by the desk top study, and no Site Investigation Report is available, a site investigation shall be made.

The procedure adopted shall be in accordance with BS 10175:2011 and a specialist contractor with appropriate experience shall be used.

The survey shall address such questions as:

- What contaminants are present, and in what concentration?
- Can the contaminants be removed?
- Can remedial work be undertaken?

### 2.4.3 Action on Contamination Reports

When the site survey report is received, a copy shall be sent to the cable Supplier, to ask if the cable they normally supply will be suitable for use in the environment of the contaminated land.

Jan 24

It is also necessary to consider whether the contaminants will affect the cable joints:

- If the joints are proprietary items, then similar enquiries shall be addressed to the supplier of the kits.
- If the joints are of in-house design and encased in material similar to the cable oversheath, then the results of the enquiries to the cable supplier shall be extrapolated to include the joints.
- If the joints are of in-house design and encapsulated in dissimilar material to the cable, then enquiries shall be made to the supplier of the encapsulation material.

Any other accessories that may be vulnerable if incorporated into the installation shall be subject to a similar procedure. This may include such items as:

- Tanks and pipes on fluid-filled systems.
- Earthing link boxes
- LV link boxes
- Earthing cables
- Cable ducts and duct seals
- Plastic cable tiles
- Marker tapes

## 2.5 Options for Installations Design in Contaminated Land

### 2.5.1 Purchase of Special Cables and Accessories

Every effort shall be made to avoid the purchase of special cables and accessories to avoid a commitment to special spares for maintenance and repairs. If it is unavoidable, however, the logistics and expense of providing the spares and repairs facility shall be incorporated into the decision-making process.

### 2.5.2 Other Options

#### 2.5.3 Re-routing the Cable

This option should have been investigated with the desktop study but may have to be re-visited.

##### 2.5.3.1 Enclosing the Cable in Special Backfill

This option is unlikely to be effective in wet areas or areas subject to methane migration.

##### 2.5.3.2 Removing the Contaminated Soil

This option is effective provided all the contaminated material is removed. If not, contaminants may leach back into the trench. The civil work and waste disposal costs may be substantial.

##### 2.5.3.3 Lining the Trench with Impervious Material or Ducting the Cable in Impervious Pipe

Of these two options, ducting the cable is likely to be more effective in the longer term provided attention is paid to the specification of the duct material. Water utility experience may be of assistance in developing a suitable specification. Precautions are necessary, however, against methane migration and there is a cost penalty arising from the reduction in the cable rating.

### 3 Documents Referenced

DOCUMENTS REFERENCED	
<b>BS 10175:2011</b>	Investigation of potentially contaminated sites - code of practice
<b>BS 7655</b>	Specification for insulating and sheathing materials for cables
<b>CIRIA Report 132</b>	A guide to safe working on contaminated sites; Steeds et al, 1996, Construction Industry Research and Information Association
<b>ERA Report 98-0416R</b>	The impact of contaminated land on buried electric cables; Billing & Greenwood; 1998; ERA Technology Ltd. ISBN: 9780700806737
<b>Department of Environment (DoE) Industry Profiles</b>	<p>The following profiles provide information on the processes, materials and waste associated with individual industries with regard to land contamination.</p> <p>They are not definitive studies, but they introduce some of the technical considerations that need to be borne in mind at the start of an investigation for possible contamination.</p> <p>They are available in pdf format from following link : <a href="http://doeindustryprofiles.claire.co.uk">DoE Industry Profiles (claire.co.uk)</a></p> <ul style="list-style-type: none"> <li>• Airports.</li> <li>• Animal and animal products processing works.</li> <li>• Asbestos manufacturing works</li> <li>• Ceramics, cement and asphalt manufacturing works.</li> <li>• Chemical works: coatings (paints and printing inks) manufacturing works.</li> <li>• Chemical works: cosmetics and toiletries manufacturing works.</li> <li>• Chemical works: disinfectants manufacturing works.</li> <li>• Chemical works: explosives, propellants and pyrotechnics manufacturing works.</li> <li>• Chemical works: fertiliser manufacturing works.</li> <li>• Chemical works: fine chemicals manufacturing works.</li> <li>• Chemical works: inorganic chemicals manufacturing works.</li> <li>• Chemical works: linoleum, vinyl and bitumen-based floor covering manufacturing works.</li> <li>• Chemical works: mastics, sealants, adhesives and roofing felt manufacturing works.</li> <li>• Chemical works: organic chemicals manufacturing works.</li> <li>• Chemical works: pesticides manufacturing works.</li> </ul>

- Chemical works: pharmaceuticals manufacturing works.
- Chemical works: rubber processing works (including works manufacturing tyres or other rubber products).
- Chemical works: soap and detergent manufacturing works.
- Dockyards and dockland.
- Engineering works: aircraft manufacturing works.
- Engineering works: electrical and electronic equipment manufacturing works (including works manufacturing equipment containing PCBs)
- Engineering works: mechanical engineering and ordnance works.
- Engineering works: railway engineering works.
- Engineering works: shipbuilding, repair and shipbreaking (including naval shipyards).
- Engineering works: vehicle manufacturing works.
- Gasworks, coke works and other coal carbonisation plants.
- Metal manufacturing, refining and finishing works: electroplating and other metal finishing works.
- Metal manufacturing, refining and finishing works: iron and steel works.
- Metal manufacturing, refining and finishing works: lead works.
- Metal manufacturing, refining and finishing works: non-ferrous metal works (excluding lead works).
- Metal manufacturing, refining and finishing works: precious metal recovery works.
- Oil refineries and bulk storage of crude oil and petroleum products
- Power stations (excluding nuclear power stations).
- Pulp and paper manufacturing works.
- Railway land.
- Road vehicle fuelling, service and repair: garages and filling stations.
- Road vehicle fuelling, service and repair: transport and haulage centres.
- Sewage works and sewage farms.
- Textile works and dye works.
- Timber products manufacturing works.
- Timber treatment works.
- Waste recycling, treatment and disposal sites: drum and tank cleaning and recycling plants.
- Waste recycling, treatment and disposal sites: hazardous waste treatment plants.

- Waste recycling, treatment and disposal sites: landfills and other waste treatment or waste disposal sites.
- Waste recycling, treatment and disposal sites: metal recycling sites.
- Waste recycling, treatment and disposal sites: solvent recovery works.
  - Profile of miscellaneous industries, incorporating:
  - Charcoal works, Dry-cleaners
  - Fibreglass and fibreglass resins manufacturing works
  - Glass manufacturing works
  - Photographic processing industry
  - Printing and bookbinding works



## Chapter 3 – General Installation Practice for Cables up to 132kV

This Chapter has been prepared as a guide to the installation practice to be adopted for all underground power and auxiliary cables up to 132kV. It is intended for use by ENWL staff and contractors' staff. The standards relating to the practice of cable installation and the completed work are covered in more detail in ENWL specifications ES400E4 and ES400E5. Only approved cables listed in [Chapter 1](#) shall be used in new installations.

This Chapter covers the basic requirements applicable in the majority of instances, i.e. cables laid directly in the ground or in ducts. Special circumstances such as cable bridges and enclosed cableways are included elsewhere in this Code of Practice.

### 1 Definitions

<b>ENWL</b>	Electricity North West Limited
<b>Engineer</b>	shall mean Electricity North West Limited Engineer or Project Organiser
<b>Site Supervisor</b>	shall mean Electricity North West Limited or Contractor's Site Supervisor, as appropriate.
<b>'Approved' and 'Competent Person' (specially 'Competent Jointing Staff')</b>	shall take the meaning given in the Electricity North West Limited Distribution Safety Rules.

### 2 Preparatory Work

#### 2.1 Notices and Consents

Before work is started on site ensure that:

- All Statutory Notices have been served by the due dates, in accordance with the requirements of the Regulations and Codes of Practice issued by the Department of Transport under the provisions of the New Roads and Street Works Act 1991.
- Any necessary Consents or Wayleaves have been obtained from Street Authorities or from any other body or person, as appropriate.

The Site Supervisor shall be informed of any conditions attaching to such Consents in so far as they could affect the carrying out of the work. The Site Supervisor shall arrange for the work to be carried out accordingly.

During the course of the work, any questions arising with third parties regarding Notices or Consents shall be immediately referred to the Engineer.

## 2.2 Reconnaissance Information

The Site Supervisor shall be informed of all relevant information gained from the reconnaissance operation. The Site Supervisor shall arrange for the work to be carried out accordingly.

## 2.3 Joint Inspection of the Route

Before starting work, and, where deemed necessary by the Engineer, a joint inspection of the route shall be carried out by the Engineer, the Site Supervisor and the Authority concerned. It is particularly important to hold site meetings to clarify accesses and methods of working before work is carried out on private land. The state of the route and any special requirements shall be recorded, using photography where this can be of assistance.

It is important for the Engineer and the Authority to agree on the current state of the surface where any special conditions apply (e.g.: number of broken flags in a path before work commences).

## 2.4 Precautions to be Taken on Sites of Special Interest

When working on land which is used for a specific purpose or by a specialised industry (where any unusual or unique conditions not covered by this chapter may apply) e.g., land owned by Network Rail, Mainline pipeline, etc - consult with the relevant authorities about any precautions that may apply, and any industry specific publications that may need to be read.

# 3 Excavation of Trenches

## 3.1 General Safety in Excavations

General safety in excavations is summarized in the HSE Information Sheet; "Excavation: What you need to know as a busy builder".

Operatives tasked with excavating may operate near large, fast moving and powerful machinery within constrictive and potentially unstable earthworks. At the same time, they may have to contend with the ever-present dangers of water entry, uncharted underground services, potentially hazardous atmospheres and falls from height. Each excavation can present a unique combination of hazards that require the work to be carefully sequenced, with appropriate control measures in place to safely manage the process. Most excavations are carried out in urban areas near the public. This requires constant vigilance and planning to protect colleagues and the public.

## 3.2 The Avoidance of Danger from Underground Services

Existing underground services shall be located and identified prior to excavation in accordance with the following documents and notes.

- Health and Safety Executive Guidance Note HS(G)47 'Avoiding Danger from Underground Services'.
- ENWL operational practice is given in Code of Practice 606
- Forks shall not be used for hand excavation.
- Exposed cables shall not be used as hand or foot holds.

### 3.3 Mechanical Excavation

Where suitable situations exist, mechanical excavation shall be used with Safe digging practices. Mechanical excavation shall be deemed to include the use of narrow trenching equipment.

Due regard shall be given to the effect of mechanical excavation on surface layer and subsequent reinstatement; in particular, no increase in trench dimensions shall be allowed. Where mechanical excavators are used, the requirements relating to backfilling in Section 6 shall still apply.

### 3.4 Trenchless Technology

Where suitable situations exist, trenchless technology shall be utilised provided that prior approval of the Engineer has been obtained.

### 3.5 Noise Reduction

Approved sound muffling devices shall be fitted to road breaking and excavation equipment at all times when in use.

The Control of Noise at Work Regulations must be complied with.

### 3.6 General

The exact location of each trench shall be approved on site. Trenches shall be kept as straight as possible and each trench shall be excavated to an approved formation and dimensions, and shall have vertical sides which shall be timbered, sheet piled, or trench sheeted where necessary so as to avoid subsidence and damage or possible injury. The bottom of each trench shall be firm and of smooth contour and free of stones and flint.

During the course of the Work the Engineer shall be informed without delay of any unforeseen features of the route which may be detrimental to the operation of the cables. Such features shall include localised situations:

- Which from a reasonable inspection may appear liable to corrosion, subsidence or vibration.
- Adjacent to extraneous sources of heat.
- Adjacent to cables which had not previously been notified to the Site Supervisor.
- Where local drainage conditions might produce a flow of water along the trench, after backfilling, sufficient to displace the backfill materials.

Where a change in level is necessary and the bottom of the trench shall rise or fall gradually, with an even gradient.

Where a change of direction is necessary, the approved bending radius and pulling tension shall applied as detailed in ES 400E4 or ES 400 E5.

In some circumstances gases may enter the excavation. These gases can potentially be fatal and should be controlled. Excavations within live highways or where plant is operating within the dig may require consideration of the potential for exhaust fumes to build up. Excavations on or adjacent to water mains, sewers or gas mains will always require consideration of the potential for sudden water entry or the build-up of toxic or flammable gas. If there is a risk of noxious fumes, you should consider how these can be ventilated or removed.

Always check that excavations do not undermine surrounding structures i.e. scaffolding, nearby buildings, walls or street lamps. Decide if extra support is needed for the structure before you start. Surveys of the foundations and the advice of a structural engineer may be required, for example, excavating near building/wall foundations.

Unless otherwise agreed, provision shall be made during excavation and until interim restoration has been completed, for reasonable access of persons and vehicles to property or places adjacent to the route. All crossing boards and gangways shall be of adequate strength for their purpose and shall be secured together (refer to Street Works Advice Notes 25).

Unless otherwise instructed by the Engineer, provision shall be made for the mechanical protection of cables, whether live or dead, and other apparatus left in unattended excavations.

### **3.7 Excavated Material, Site Restrictions and Guarding of Road Works**

The works shall be carried out in a clean and tidy manner with full consideration for the needs of others.

The material excavated from each trench shall be placed so as to prevent nuisance or damage to adjacent hedges, trees, ditches, drains, gateways, cultivated grass and other property or things. Excavated materials shall be stacked so as to avoid undue interference with pedestrian and vehicular traffic and commerce.

It must be ensured that the excavated material do not overload the trench edges and that the material does not block surface water drains or otherwise obstruct the free passage of surface water. Additionally, a walkway must be left on at least one side of the trench to facilitate inspection and pedestrian access.

Where, owing to traffic or other considerations, this is not possible, the excavated material shall be removed from the site and where required shall be returned on completion of cable laying.

Where the obstruction due to site works will be such that it is considered necessary to close the road to traffic, the Engineer or Site Supervisor shall obtain the agreement of the Street Authorities or Street Managers concerned to temporarily close the section of the road so affected.

New materials must be used for reinstatement. For more information on reinstatement materials, refer to ES400R5).

Exceptionally, where excavated materials can be re-used for reinstatement of road foundations, the excavated road surface materials and base foundations shall be separately stacked from the excavated subsoils. Similarly, topsoil shall be stacked separately when excavating in agricultural land. Turfs, chippings and the like shall be removed over an agreed width on either side of the trench, to reduce the possibility of damage and/or contamination to those surfaces adjacent to the trench line.

When the cable trench is routed through property other than public roads or pathways, information concerning the appropriate conditions agreed with the owner and occupier shall be provided by the Engineer.

Any surplus material which is identified as poisonous, noxious or polluting or which could constitute an environmental hazard shall be reported to the Engineer who will then agree the work to be carried out.

The disposal of such waste shall be in accordance with the provisions of the Environmental Protection Act.

Any excavation including a joint hole must be suitably lit, signed and guarded at all times to prevent danger to the person(s) working in the excavation and the public and other persons, who could be nearby. Work shall at

all times be carried out in accordance with the Code of Practice the 'Code of Practice for Safety at Street Works and Road Works' (Red Book) issued by the Department of Transport under the New Roads and Street Works Act 1991.

### 3.8 Obstructions

Adequate measures shall be taken to support and protect from damage any services, apparatus or other equipment situated in or adjacent to the work. When obstructions due to third party plant are encountered, or alterations to buildings or foundations are required or a special form of trench is necessary, the Site Supervisor shall immediately notify the Engineer, who will then give instruction, in writing, to proceed with such work as may be necessary.

### 3.9 Joint Bays

Joint bays shall be constructed to enable jointers to carry out their work safely and efficiently and shall be approved by the Engineer.

The historic version of Regulation 8 of the Construction (General Provision) Regulations 1961 stated that; "any excavation deeper than 1.2m deep where there is a risk of material collapsing or falling, proper timbering, trench sheeting etc, must be used to safeguard operatives". However this regulation was withdrawn when the CDM (Construction & Design Management) Regulations came into effect which now state; All practicable steps shall be taken to prevent danger to any person, including where necessary, the provision of supports or battering to ensure that any excavation or part of an excavation does not collapse, that no material from a side or roof of or adjacent to, any excavation is dislodged or falls and no person is buried or trapped in an excavation by material which is dislodged or falls. It is important that operatives in the field remember that when excavating 1.2m is no longer a reference point or indicator in regard to trench / excavation supports, depending on the ground condition and environment of where the work is being carried out. Trench / excavation supports may be required at any trench / excavation depth.

Joint bays shall be constructed in accordance with ENWL Code of Practice 411 Pt1, 411 Pt 2, or 412. The sides of each joint bay shall be timbered, sheet piled, or trench sheeted where necessary to avoid subsidence and damage or possible injury. Safety Access needs to be provided by formed steps or ladders.

In joint bays, horizontal railings shall additionally be supported by vertical struts.

The cable shall be suitably supported from the joint to the cable trench to prevent settlement of the cable that could impose strain at the joint entry.

### 3.10 Thrust and Auger Borings and Headings

Where site conditions necessitate thrust or auger bores, or headings, the type of operation and the positioning shall be approved by the Engineer based on all information available regarding existing services, installations, sub-soils and water levels. Where this information is either not complete or not reliable, then trial holes or trial bores shall be undertaken in order to obtain the additional information.

No heading shall be driven except on the instruction of the Engineer, in writing; before each heading is driven, a drawing shall be prepared showing the constructional details of the heading, the proposed method of back filling and the position and depths of all known obstructions to be crossed. Such drawings are to be Approved by the Engineer.

## 4 Timbering of Excavations

### 4.1 General

All reasonable precautions shall be taken to prevent danger or damage to the highway or ground surface from a slip or breaking away of the sides of the trench. The trench excavation and filling in shall be so executed as to be reasonably secure against risk of subsidence or injury.

Work in an unsupported or inadequately supported excavation can be particularly hazardous as the short-term stability of exposed faces is difficult to judge. The consequences of sudden ground collapse or cave-in when a colleague is not protected by an appropriate excavation support system are often serious or fatal. Collapse injuries are typically caused by impact, crushing or asphyxiation.

Collapses are commonly attributed on site to:

- Inconsistency, and therefore unexpected instability, of the material being excavated, particularly in made or previously disturbed ground
- Surcharging and/or vibration around the edge of the excavation such as the operation of heavy plant or the stockpiling of excavated materials in close proximity to the excavation.
- Weather conditions and/or groundwater flows adversely affecting soil properties
- Poor understanding on site of potential earthworks failure mechanisms
- Poorly executed or inappropriate temporary support solutions

The vast majority of excavations created in the ENWL region are relatively shallow and in urban areas, where the ground has probably been re-worked several times. Made ground is particularly variable in terms of composition and behaviour and exhibits large variations in strength and stability.

### 4.2 Dangers

The following items are to be taken into account to determine if an excavation shall require additional measures to make safe i.e. shoring or battering back (making the excavation wider on all sides by reducing the angle of the ground and the chance of the ground collapsing into the excavation): -

- **The stability of the ground** – loose ground may cause material to fall into the excavation. Collapse of excavations can be prevented by battering back the excavation sides to a safe angle, in granular soils (i.e. made up of small particles) the angle of slope should be reduced and in wet conditions a considerably flatter slope will be required.
- **Weather conditions** – rain can cause firm ground to become unstable and collapse, also dry weather conditions can quickly change to rain. The weather can play a large part in the deterioration of excavations and as such should be monitored before, during and after excavations have been completed.
- **Depth of excavation** - it should be noted that there is no safe minimum depth of excavation. Previously in the UK Construction Industry it had been standard practice to provide shoring for any excavation beyond 1.2m in depth when persons were required to enter the excavation.
- **Spoil** – spoil should either be removed from site or placed a minimum of the depth of the excavation away from the side or edge, otherwise the depth of spoil contributes to the overall depth of the

excavation as well as causing additional surcharge. Also, where necessary, the spoil should be stabilised to prevent it falling into the excavation.

- **Nearby passing traffic** – depending on the location of the excavation, heavy traffic can cause vibrations in the ground, potentially loosening the substructure.
- **Falling into deep excavations** – edges of excavations should be protected with substantial barriers (E.g. Heras fencing) where people are liable to fall into them.

### 4.3 Specific Requirements

Skeleton timbering shall always be installed where required based on ground conditions.

Open or Close Boarded timbering shall be employed in all excavations where required based on ground conditions.

All timbering shall be installed as excavation proceeds so far as is reasonably practicable.

All timbering shall be regularly checked when in use to ensure its condition by a competent person.

On completion of the work, timbering shall not be left in situ without the prior approval of the Engineer.

### 4.4 Materials

All timber to be used for support purposes shall be maintained in a sound condition to the satisfaction of the Engineer.

The normal dimensions of timber used for trench supports shall be in accordance with the following list, but in no case shall be less than 25mm thick unless otherwise approved by the Engineer.

<b>Poling Boards</b>	225 x 38mm
<b>Waling Boards</b>	225 x 75mm
<b>Struts *</b>	100 x 100mm
* Wooden struts may be replaced with an adjustable metal type.	

### 4.5 Types of Timbering to be Employed

Timbering of excavations shall be carried out in one or more of the following forms.

#### 4.5.1 Skeleton Timbering

This shall comprise vertical poling boards and horizontal-bracing struts generally as shown in Drawing [HQ.A4.52.09-247](#) and no horizontal walings shall be utilised. Skeleton timbering consists of units placed at intervals of not less than 3m. If units are required at more frequent intervals, then open or close board timbering shall be employed.

#### 4.5.2 Open Boarded Timbering

This shall comprise vertical poling boards, placed along the side of the excavation, and the space between adjacent poling boards must not exceed 0.15m. The poling boards shall be supported by a horizontal waling

of adequate size and strength, and the walings shall be suitably braced by struts. This arrangement is generally as shown in Drawing [HQ.A4.52.09-247](#). Boards shall not protrude above ground.

#### 4.5.3 Close Boarded Timbering

This shall be of similar arrangement to open boarded timbering with the provision that the vertical poling boards must abut.

#### 4.5.4 Timbering in Abnormal Circumstances

Guidance on the type of timbering to be used in specific circumstances may be obtained from BS 6031 (1981) 'Code of Practice for Earthworks'.

#### 4.5.5 Inspections

Once a shored or battered back excavation is completed by a contractor, to maintain the required precautions and meet the requirements of the Construction (Design & Management) Regulations, Regulation 22, statement 4, a competent person must inspect the shoring or battering at the start of the work, at the start of each new day or after any event that may have affected its strength or stability, including after a fall of earth, and remedial action taken where necessary.

## 5 Cables Laid in Trenches and Ducts

### 5.1 Position and Depth of Cables

Cables up to and including 11kV shall, wherever possible, be laid in accordance with the recommendations of NJUG Publication No 7 'Recommended Positioning of Utilities' Mains and Plant for New Works' except that depths shall be as indicated in ES 400E4 or ES 400E5.

33kV and higher voltage Cables shall (for preference) be laid in grass verges, central reservations or uncongested wide footpaths (in the latter case consideration must be given to the possibility of other cables being installed in an adjacent position at some future date). If these positions are already fully occupied, then they shall be laid in a carriageway approximately 1m from the kerb.

Pilot cables shall wherever possible be laid adjacent to the associated HV cable but maintaining a minimum separation of 50mm from all power cables.

The Engineer shall give instructions in respect of the exact location of cables in the excavations, the distance between centre lines of adjacent cables or groups of cables and the location of auxiliary cables with respect to power cables.

Unless otherwise instructed by the Engineer, single core cables forming one three-phase circuit shall be laid in close trefoil formation, and the formation shall be bound together with nylon cable ties at intervals not exceeding 1.5m.

Where more than one horizontal layer of cables is laid, the level of the upper layers of cable shall be gauged from the level of the finished bottom of the trench and marked on the side of the trench at frequent intervals before installation of the lower layers, to ensure that the correct vertical spacing is maintained.



Tree roots may disturb the positions of cables and increase difficulties when excavating later. Figure 1 below provides the preferred distances to be maintained where practicable between laid cables and tree types.

**Figure 1 – Recommended distance of trees from cable positions**

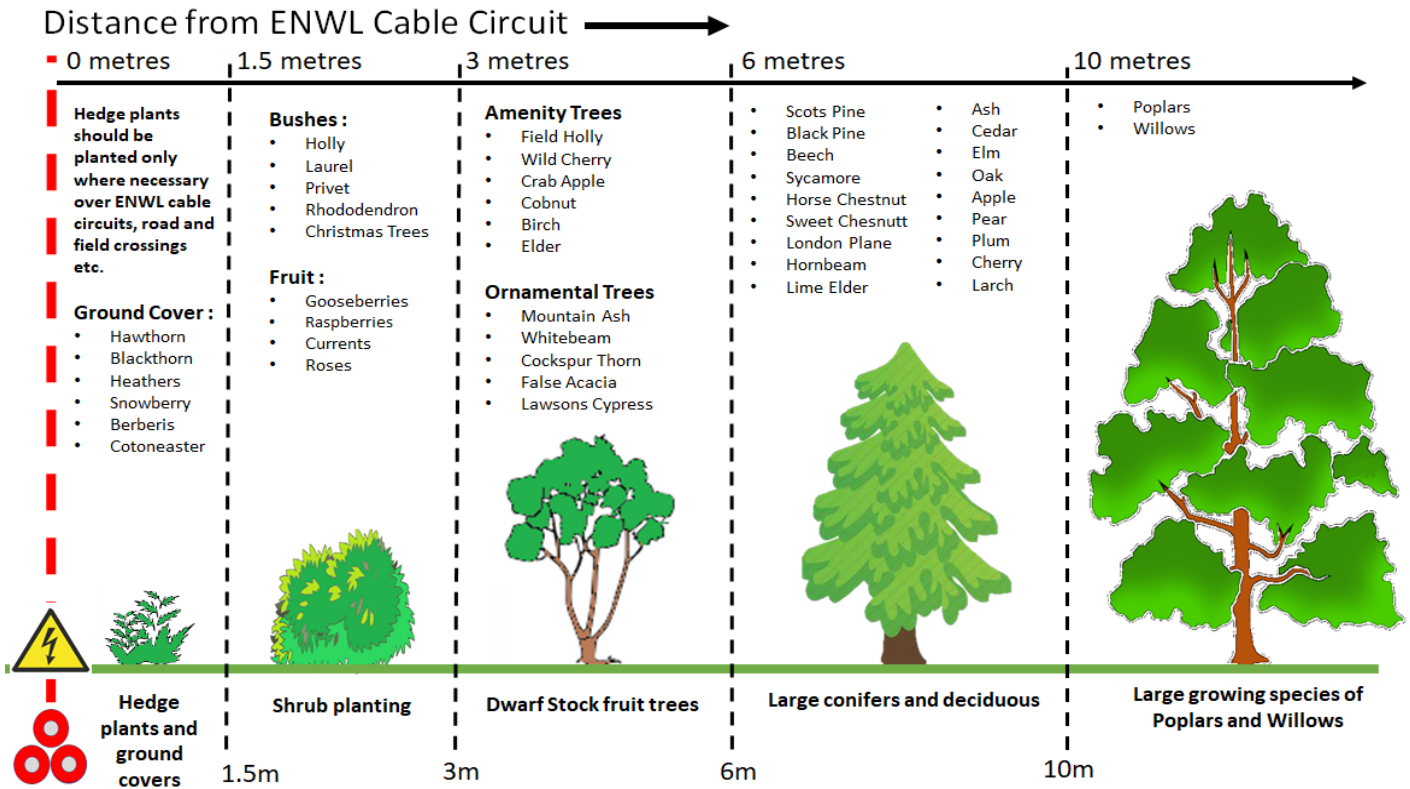

### 5.3 Bending Radius of Cable

No cable shall be installed with a bending radius less than that shown in the relevant ENWL jointing manuals (Code of Practice 411 Pt1N, 411 Pt 2, 412,414) or ES400E4 / ES400E5.

### 5.4 Cable Protection Covers and Other Warning Devices

The mechanical protection of underground cables when laid direct shall, unless otherwise specified by the Engineer, be in accordance with ES 400E4 or ES 400E5

#### 5.4.1 Method of Laying Concrete or Plastic Covers

The width of cover shall be such that there is a minimum 50mm overlap on each side of the cable or outside cable of a group of cables. If more than one cover is proposed for covering a group of cables, the width chosen shall be such that the longitudinal joint between the covers lies above the space between the cables and not immediately above a cable.

Unless otherwise indicated by the Engineer, covers shall be positioned 40mm from the top of the cable.

The covers shall be laid evenly and follow the contour of the cable being protected.

Chipped, cracked or otherwise damaged covers shall not be installed.

#### 5.4.2 Method of Laying Plastic Marker Tape

Plastic marker tape shall comply with ES 400TT1, and shall be laid as follows:

- The tape shall normally be laid centrally over the cable or in such other position as the Engineer may instruct. Under some circumstances the Engineer may require the positioning of 2 widths of tape continuous in the horizontal plane. Unless otherwise indicated by the Engineer, tapes shall be positioned 200mm over the top of the cable.
- The tape shall be laid evenly and follow the contour of the cable. The layer of backfill immediately underneath the tape shall be properly consolidated in such a manner that the completed work is to the satisfaction of the Engineer. Where necessary, this consolidation shall be in addition to that required elsewhere.
- At joins in the tape there shall be an overlap of at least 300mm.
- Torn, damaged or illegible tape shall not be installed.

### 5.5 Pipes and Ducts for Cables

Ducts shall be of approved type, materials and construction and in accordance with ENA TS 12-24.

The approved size range of cable ducts is contained in the table below. Normally the Recommended duct given in the table shall be used. The Engineer may authorise the use of one of the other Approved ducts in special circumstances.

### 5.5.1 Table A1– Pipes and Ducts for Cable

TYPE OF CABLE	CABLE SIZE mm <sup>2</sup>	OVERALL DIAMETER mm	NOMINAL ID/OD OF DUCT mm
LV Service Cables CNE & SCNE Single phase	Up to & including 25mm <sup>2</sup> copper / 35mm <sup>2</sup> aluminium	Up to 22mm	32/38 mm
Other service cables		Up to 22mm Greater than 22 mm	32/38 mm 103/110 mm
LV Waveform	95 185 240 300	34.5 45.9 50.7 55.3	103/110mm
11kV Polymeric	95 triplex 185 triplex 300 triplex 400 triplex	61.0 70.5 81 90	150/160mm
	400 single formation (1 phase per duct)	40	103/110mm
33kV Cable	All types		150/160mm or 188/200mm

**NOTE:**

- (a) For cables not covered by above table, select duct size that will give a minimum of 35mm difference between the internal diameter of the duct and the cable overall diameter.
- (b) Where single core ac cables are individually drawn into separate ducts non-metallic ducts shall be used.
- (c) Split ducts may only be used when required by the Engineer.

### 5.5.2 Installation of Pipes and Ducts

Pipes, ducts and troughs through which cables are to be drawn or laid shall be installed to the satisfaction and Approval of the Engineer.

No cracked, chipped or otherwise damaged pipes, ducts or troughs shall be installed.

It must be ensured that all pipes, ducts or troughs are level or otherwise evenly follow the contour of the trench bottom.

The Engineer may instruct that pipes, ducts or troughs shall be bedded or haunched in concrete of Approved constitution, to a given thickness.

After these items have been laid, they shall be cleaned through and adequate precautions taken to prevent the ingress of foreign material up to the time when the cables are installed.

The Engineer shall require the bores to be tested for smoothness by the drawing through of a metal mandrel of slightly less diameter than the duct internal diameter, unless specified otherwise.

When the cable is to be bond pulled, a separate duct shall be installed to take the bond wire during installation. The bond duct is to be so positioned that the length of unsupported cable on emerging from the duct is reduced to a minimum.

Cables leaving and entering duct mouths shall be adequately supported to eliminate the possibility of damage to the cables.

### 5.6 Filling of Pipes or Ducts

Where required by the cable system design in order to provide uniformity of constraint against thermo-mechanical forces and/or thermal equivalence to the directly buried parts of the route, the pipes or ducts shall be completely filled with a bentonite-sand-cement (or equivalent) mixture in an approved manner after cable installation.

The method of working is further described in ENA TS 09-2.

## 6 Bedding, Blinding and Backfilling

All materials used for reinstatement shall meet the requirements of ES400R5.

### 6.1 Approval Prior to Backfilling

The cables, pipes, ducts, troughs, joints, or any other apparatus in the excavations must be inspected before any backfilling is commenced.

### 6.2 Method of Backfilling

All excavations shall be so backfilled that the cables, ducts, pipes, troughs, joints or any other apparatus are not damaged during the work, or by any external pressure when the ground is returned to normal use. The excavations shall be backfilled in layers not exceeding 100mm thick, each layer to be properly rammed and consolidated in such a manner that the completed work is in accordance with the Code of Practice 'Specification for the Reinstatement of Openings in Highways' issued by the Department of Transport.

### 6.3 Bedding and Blinding

All such materials shall conform to the requirements of ES400R5.

All accumulated water shall be pumped from the excavation before blinding the cable or duct. Unless otherwise approved, cement bound materials including foamed concrete shall not be used as a material for surrounding cables.

No work associated with either excavation or backfilling shall take place in the proximity of a recently made cable joint until any resin comprising part of the joint has cured to the stage where it is solid to the touch. This initial amount of curing is necessary to prevent the moisture seals in the joint from being disrupted by mechanical interference. Do not use any backfill with sharp objects or boulders that could pierce the joint shell or build up damp soil around the joint shell until the resin has cured.

Where circumstances make it necessary, surround material as specified above shall be used as bedding for cables. Surround material (above the cable prior to backfilling around the cable and other apparatus installed in open trenches) shall be used to a thickness as follows:

- Low voltage system: thickness = 100mm ± 10%.

- High voltage system: thickness = 100mm ± 10%.

Refer to ES 400E4 or ES 400E5 for further detail.

Power rammers shall not be used to consolidate the first layer of backfill, i.e. all bedding and blinding to a level of 225mm above the cable. It may sometimes be possible to use vibratory consolidation equipment for this purpose.

Exceptionally, the excavated material may be used as bedding for the cable. In such a case, the engineer must decide whether or not the material is suitable.

In order to provide suitable thermal characteristics and also to avoid damage to cable servings, sand or other materials imported for bedding and blinding shall be of acceptable particle size and grading; sand shall be completely free from any material, which may have a deleterious effect upon the cable.

The Site Supervisor shall inform the Engineer of any material encountered during excavation work, which may produce chemical or electrolytic action with the cable or have toxic effect.

#### **6.4 Materials for Backfilling**

All materials used for reinstatement shall meet the requirements of ES400R5.

No material containing stones, flints or similar foreign materials shall be placed immediately adjacent to the cables, or between the cables and any protection covers.

#### **6.5 Cables and Mortar**

The Engineer may require the supply and placement of concrete of Approved constitution and thickness for the support of ENWL or any other equipment. The materials used for concrete and mortar shall comply with the relevant sections of the appropriate British Standards.

The mixing and placing of concrete shall be carried out in accordance with good practice as set out in BS 8000:Part 2.

Concrete or mortar shall not be mixed or placed when the air temperature is less than 3°C unless approved precautions are taken. Concrete shall not be poured against frosty shutters or frozen ground. Similarly, mortar shall not be placed against frosty surfaces including pipes or bricks.

Finished concrete surfaces shall be kept moist and protected from the drying effects of wind and sun by the use of polythene sheets or other approved means for a period of 7 days after casting.

#### **6.6 Site Clearance**

On completion of the excavation and interim restoration, all rubbish, debris, unused materials, litter, temporary huts and other erections, equipment and apparatus shall be removed from the Site. The Site shall be left in a satisfactory condition that meets the Approval of the Engineer, the Street Authority or any other body or person interested.

## 7 Equipment for Cable Laying

### 7.1 Winches

#### 7.1.1 Design

Winches shall be of Approved design and maintained to the satisfaction of the Engineer at all times.

#### 7.1.2 Tension Control

The maximum pulling tensions shall not be exceeded (Refer to ES400E4,ES400E5 or manufacturers datasheets). It is preferred that each winch shall be fitted with an accurate tension-limiting feature. In this case:

- The tension limit on any particular pull must not exceed the maximum value acceptable to the Engineer for the particular cable concerned, and
- The accuracy of the tension-limiting device must be maintained at all times over its complete range of adjustment.

Where such a tension-limiting device is not fitted then the pulling in arrangements must incorporate an alternative accurate and efficient device for measuring the tension applied to the cable; in this event the provision of the second point above shall apply to the measuring device. The measuring device must be continuously observed throughout the duration of the cable pull

### 7.2 Cable End Attachments

In all cases where tension is applied to the end of the cable, the following provisions shall apply:

#### 7.2.1 Pulling Eye

An Approved pulling eye (when supplied with the cable) must be used for the attachment of the pulling bond in those circumstances where end pulling is Approved.

#### 7.2.2 Cable Stockings

No power cable in this category shall be installed by the method of nose pulling using a cable stocking only.

#### 7.2.3 Pulling Eye for 33kV XLPE Cables

If a cable end is stripped to allow a fitting to be connected to the conductor for pulling in, it is important that the exposed conductor and fitting are sealed against moisture ingress before pulling in commences. Self-amalgamating tape, PVC tape, and/or heat shrink are suitable materials for this purpose. See [Drawing number HQ.A4.52.30-33](#) for details.

#### 7.2.4 Pulling Eye for 132kV XLPE Cables

Where a pulling eye is fitted to a 132kV XLPE cable, it shall effectively anchor the conductor and sheath together, and shall also be designed to seal the cable end against moisture ingress. Factory fitted pulling eyes are preferred for manufactured section lengths in a project.

#### 7.2.5 Swivel Eye

In all cases an efficient swivel eye shall be fitted between the pulling bond and the pulling attachment on the cable. The design of swivel shall be in accordance with any recommendations from the winch manufacturer.

## 8 Method of Pulling in Cables

### 8.1 Notification and Supervision of Pulling In

The Engineer shall be given at least 48 hours' notice of the intention to pull in cables.

EHV Cables shall not be pulled in unless the Engineer or his nominated representative and, where applicable, the Contractor or his representative are on site; pulling in shall not commence until all the excavation work and pulling in preparations have been completed to the satisfaction of the Engineer or his nominated representative.

Minimum cable bending radii shall be observed at all times.

Sufficient labour and equipment to install the cable without causing damage to it or other services shall be used at all times.

Before pulling in of the cable a check shall take place that the cable details as shown on the drum are in accordance with his requirements and that the diameter and external appearance of the cable appear to comply.

### 8.2 General Approval of Method

The method of pulling in cables shall be in accordance with this document wherever applicable. [Section 8.4](#) contains a number of stipulations with regard to the choice of manual or winch pulling of the various designs of cable. Irrespective of anything contained in that clause, full consideration must be given to the following before the choice is made and during the pulling in operation.

Adequate precautions must be taken to ensure the free rotation of the drum without assistance from the tension in the cable. Sufficient personnel shall be stationed at the drum for this purpose and careful attention shall be paid to the setting up and levelling of the drum and its supporting arrangements. Care shall be taken to provide adequate lubrication at all appropriate bearing points.

Care shall be taken to obviate any possibility of snatch loads being applied to the cable and every effort shall be made to ensure that the cable pulling proceeds without pause wherever possible.

Adequate arrangements must be made for efficient and prompt braking of the drum as necessary.

All equipment used in connection with pulling in shall be of sound design, construction and maintained. Cable rollers, skid plates, ramps and other equipment that may be in contact with the cables shall be of Approved design and dimensions and shall be free from sharp edges, corners and projections that could cause damage.

When pulling in cables, cable rollers must be spaced at intervals not exceeding 3m. Careful attention shall be taken to ensure the correct lining up and setting of rollers and skid plates which must be adequately lubricated; lubricants which may come into contact with PVC oversheaths shall be Approved.

Efficient arrangements shall be made for signalling along the route simultaneously to both the leading and drum ends of the cable.

The leading end of the cable must be closely attended and supervised during its progress along the route in order to ensure a smooth and unimpeded passage.

Due regard shall be paid to the likely or actual effects of all bends, ducts, changes of level and other significant features of the route taking into account their physical dimension and relative position in the route. Where necessary use shall be made of methods involving 'flaking' the cable, applying a pull to the cable at more than one position, or bond pulling. Full consideration shall be given to the size, length and design of the cable concerned. In particular, care shall be taken to avoid twisting the cable.

Under no circumstances shall Approval be given to the attachment of any pulling equipment to any substation, switchgear, equipment, fence, building or any other structure on site.

Where aluminium sheathed cables are used particular care shall be taken to prevent flattening or distortion of the sheath.

Particular care shall be taken throughout the entire installation operation to prevent damage to the PVC or similar oversheath of cables provided with this type of protection.

Cables shall not be drawn in by moving vehicles.

### 8.3 Methods of Winch Pulling – General

#### 8.3.1 Bond Pulling

The general principle of bond pulling is as shown in [Drawing HQ.A4.52.09-174](#).

- A steel wire bond, which shall be at least twice the cable section length, is run out through the whole length of the trench over cable rollers positioned in the trench in the line, which the cable is to follow.
- The cable shall be tied to the bond at no greater than 2m intervals along its entire length. Where large diameter cables are to be installed or the cables are to be installed on a steep incline or down a shaft, the number of ties shall be increased.
- At each change of direction, the ties shall be released, and the cable taken round the bend using a series of vertical skid plates and horizontal rollers, the bond wire passing through a snatch block. Particular attention must be given to the securing of snatch blocks in order to prevent their breaking free in use. The cable shall be re-attached to the bond immediately after the change of direction.
- The nose of the cable shall be guided over the corner rollers ensuring that a positive tension is maintained on the nose of the cable to prevent the build-up of slack at the bend. The equipment, location and installation of pulley blocks, arrangement of cable ties and all other arrangements in respect of bond pulling shall be subject to approval.

#### 8.3.2 Nose Pulling

When nose pulling a cable, the route requires careful design to minimise the number of bends and restrictions and must ensure that the maximum cable design pulling tension and side pressure are not exceeded.

- Where possible, the cable drum shall be sited at the joint position nearest the first bend on the section.
- For pulling, a wire bond shall be attached to the nose end of the cable via an Approved cable end attachment.



### 8.3.3 Combined Bond and Nose Pulling

Where a duct run occurs on a route where the cables are being bond pulled, the ties shall be removed from the cable where it enters the duct and replaced when it emerges from the other end. The bond shall be taken separately through an adjacent spare duct. The cable shall then be nose pulled through the duct.

### 8.3.4 Safety During Winch Pulling

Precautions shall be taken on site to protect personnel and the general public from the possible hazards associated with applying tension to wire ropes. In particular:

- Adequate warning and/or barriers shall be used where it is necessary for a wire rope/cable to pass along a pavement.
- Personnel shall be instructed not to stand in hazardous positions, for instance on the inside of bends where the wire rope could ride up out of the trench.
- No work to bolster up rollers or skid plates shall be undertaken without first stopping the pull.
- An agreed and understood system of signalling shall be operated between the operatives on the cable leading end, the drum and the winch.
- Any damage to a wire rope, e.g. distortion due to heavy impacts or broken strands, shall be examined, and if necessary the rope shall be replaced.

## 8.4 Approved Methods

### 8.4.1 XLPE Insulated Cables (except 132kV)

Wherever practical the cables shall be manually pulled in and any tension applied to the end of the cable shall be strictly limited and closely controlled.

If winch pulling is necessary, then either the bond pulling method must be used or the tension applied directly to the cable conductor. **On no account must a cable stocking be used.**

Maximum pulling tensions stated in manufacturers data sheets should be observed.

### 8.4.2 XLPE Insulated 132kV Cables

The precautions to be taken shall be generally as for all other XLPE cables except as follows when end pulling is adopted:

- The conductor and sheath shall be anchored together by use of a factory fitted pulling eye.
- The pulling tension shall be limited to 50N per mm<sup>2</sup> of conductor cross sectional area or 20kN, whichever is the smaller.

## 8.5 Pulling through Pipes and Ducts

### 8.5.1 Bell End Adaptor

Approved bell end adaptors shall be fitted to the mouth of any pipe or duct prior to the drawing through of cables. Ducts shall be brushed clear prior to installing cables.

### 8.5.2 Test Length

Where considered necessary, a test length of cable of equivalent diameter and finish to the cable to be installed shall be pulled through.

## 8.6 Low Temperature Conditions

### 8.6.1 Minimum Pulling Temperature

The cables shall be installed only when both the cable on the drum and the ambient temperature in its immediate locality are at or above 0°C and have been so kept for the previous 24 hours.

### 8.6.2 Arrangements for Ambient Temperatures Below 0°C

Where it seems likely that, in the 24 hours period preceding a cable pull, the ambient air temperature will be below 0°C arrangements shall be made to maintain the cable on the drum and its immediate surrounding air above 0°C.

## 8.7 Safety When Handling Cable Drums

The following precautions shall be taken when manually handling cable drums, both full and empty:

- Before rolling the drum, it shall be examined for rot or other dangerous deterioration and appropriate action taken.
- Stout gloves shall be worn. Safety footwear and safety helmets shall be worn where appropriate.
- Drums shall always be pushed in the direction of travel and never pulled with the back to the drum.
- Push squarely on the drum flanges, looking out for projecting nails used to retain the battens and keep fingers clear of the drum bolt heads.
- Under no circumstances shall a drum be pushed and then released so that it travels uncontrolled.
- When steel binding straps are removed care shall be taken to restrain them from springing upwards and causing injury. Approved eye protectors shall be worn.
- Drums shall be adequately chocked when stationery on the ground.
- All empty cable drums shall be returned to the Stores for their safe disposal or return to the manufacturer.

## 9 Additional Work

### 9.1 Sealing of Ducts

### 9.2 General

All new ducts shall be sealed to ES 400D5.

### 9.3 Recovery of Cables

The Engineer shall specify in writing the cables to be recovered and in particular shall detail the lengths and sizes of the cables concerned.

### 9.4 Safety

Under no circumstances shall any cable that is connected to the system be cut into by any person other than Competent Jointing Staff having specific instructions from the Engineer to do so. Safety documents shall be issued where applicable.

The Engineer shall ensure that all the procedures required by the ENWL Distribution Safety Rules together with all the ENWL standard procedures for the identification of cables, are fully satisfied before commencement of work and during the progress of the work.

The Site Supervisor shall ensure that every instruction and directive given to them by the Engineer is fully complied with.

### 9.5 Returns Procedure

The 'Procedures for Recovery, Collection and Sale of Scrap Cable, Other Conductors and Similar Materials' as contained in the ENWL Purchasing and Stores Procedure, are adhered to.

### 9.6 Cutting and Temporary Capping of Cables

Cables shall be cut and temporary end caps shall be applied in accordance with the relevant jointing manual (Code of Practice 411 Part 1 (LV), 411 Part 2 (11kV), 412 (33kV Solid)).

9.6.1 Drawing No HQ.4.52.30-33

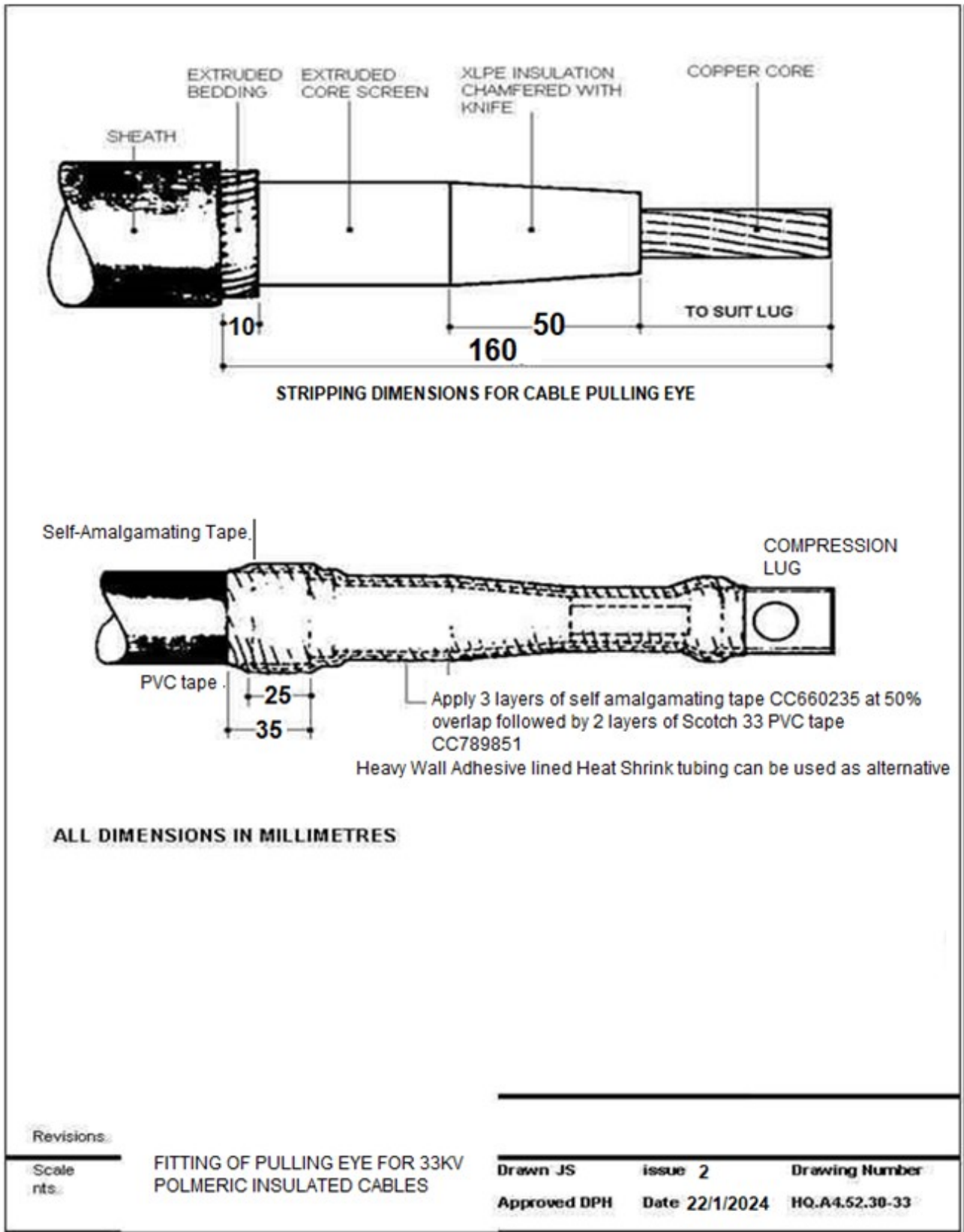

9.6.2 Drawing No HQ.A4.52.09-174

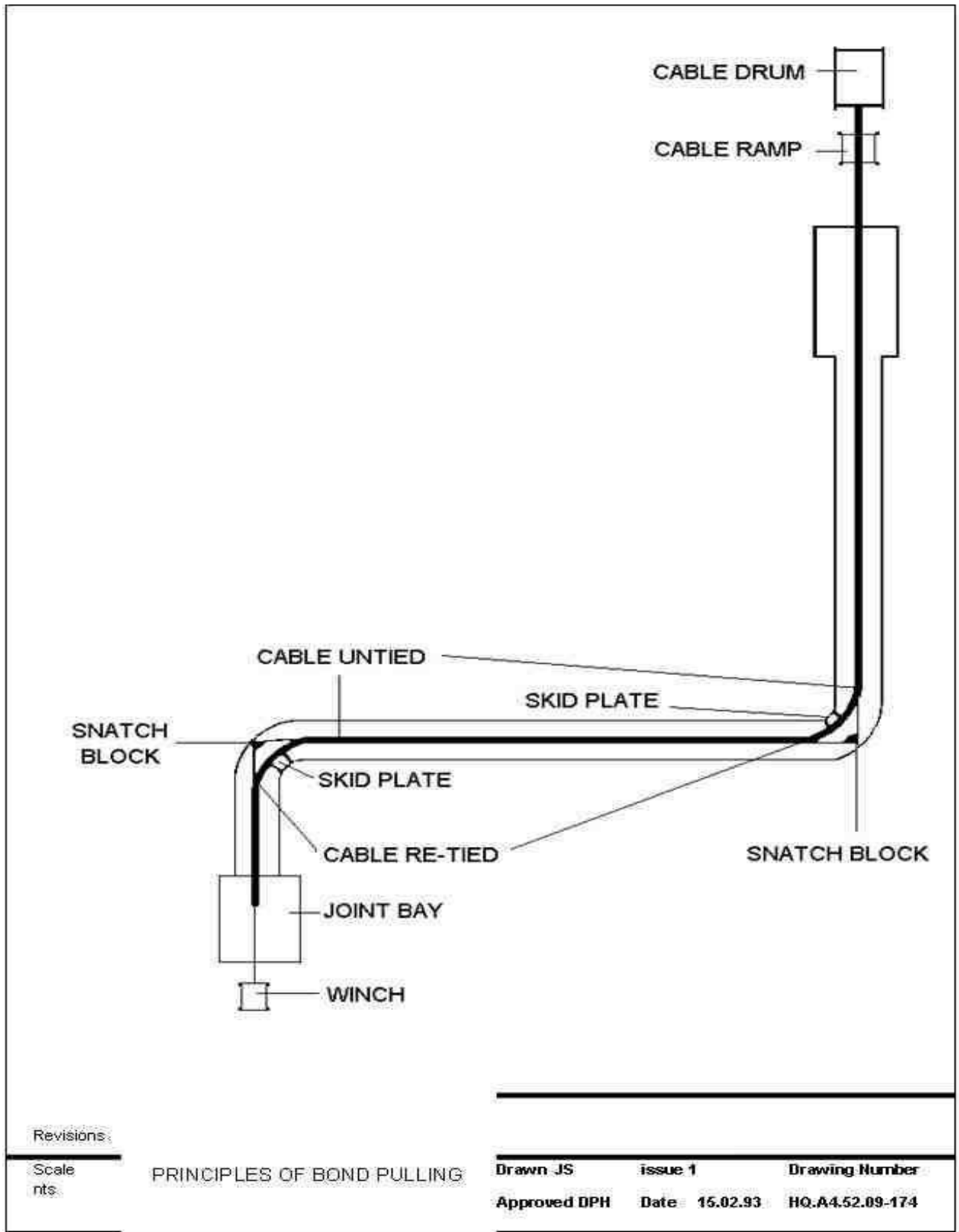

9.6.3 Drawing No HQ.A4.52.09-247

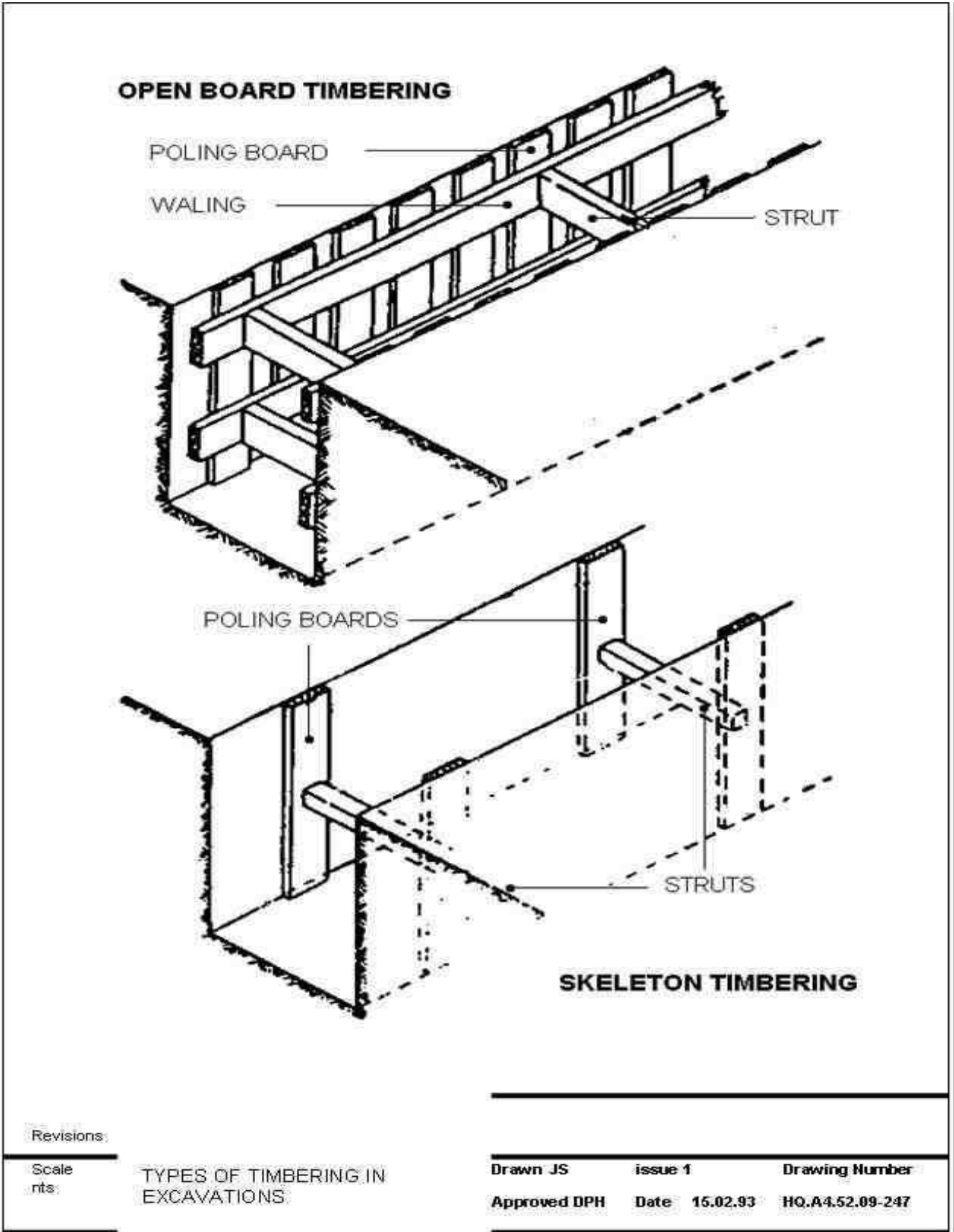

## 10 Documents Referenced

DOCUMENTS REFERENCED	
<b>New Roads and Street Works Act 1991 (NRSWA)</b>	
<b>Environmental Protection Act 1990</b>	
<b>The Control of Noise at Work Regulations 2005</b>	
<b>HSE Information Sheet</b>	Excavation: What you need to know as a busy builder <a href="https://www.hse.gov.uk/excavation/">Excavation (hse.gov.uk)</a>
<b>HSE Guidance Note HS(G)47</b>	<a href="https://www.hse.gov.uk/guidance/hsg47/">Avoiding danger from underground services - HSG47 (hse.gov.uk)</a>
<b>BS 8000</b>	Workmanship on Construction Sites
<b>BS 6031: 2009</b>	Code of Practice for Earthworks
<b>ENA TS 09 02</b>	Specification for the supply, delivery & installation of power cables with operating voltages in the range 11 kV to 400 kV and associated auxiliary cables
<b>ENA TS 12-24</b>	Plastic Ducts for Buried Electric Cables
<b>ENWL Code of Practice CP606</b>	Operations Manual
<b>ENWL Code of Practice CP411 Part 1</b>	Cable Jointing up to and including 1000Volts
<b>ENWL Code of Practice CP411 Part 2</b>	Jointing Procedures for 6.6/11kV
<b>ENWL Code of Practice CP412</b>	Jointing Procedures for 33kV Solid Cables
<b>ENWL Code of Practice CP414</b>	Jointing Procedures for 33kV Gas Filled Cables
<b>ENWL Specification ES 400E5</b>	Specification for Installation and Commissioning of Underground Cables Operating At 33kv and 132kv, and the Restoration of Excavated Areas
<b>ENWL Specification ES 400R5</b>	Specification for Materials for General Restoration of Roads and Footways
<b>ENWL Specification ES 400D5</b>	Specification for Duct Seal
<b>ENWL Specification ES 400TT1</b>	Specification for Polyethylene Warning Tape, Protection Tape and Protection Tiles for Underground Cables

## Chapter 4 – Cable Drums

This chapter covers storage, handling and transport of all HV and LV Mains cable and cable drums used by Electricity North West Limited (ENWL).

### 1 Definitions

<b>Bowden cable</b>	A flexible cable used to transmit mechanical force or energy by the movement of an inner cable relative to a hollow outer cable housing
<b>ENWL</b>	Electricity North West Limited
<b>MBD</b>	Minimum Barrel Diameter
<b>UV</b>	Ultra-Violet

### 2 Storage of Cable Drums

The following requirements shall be met during storage:

- Cables stored at temperatures which are below those recommended for installation by the manufacturers shall not be subjected to any mechanical stress, i.e. shocks, impact, bending or torsion.
- Drums shall be stored on a flat, firm, even and well-drained surface, in an upright position; using wedges in the heels of the flanges.
- They shall not be stored on their side or stacked, i.e. flange on flange.
- Drums shall be stored so that the drum flanges do not touch cable on another drum.
- Where drums have been supplied with battens already applied, these shall be left in place. Drums that have been supplied without battens, or drums where battens have been removed, shall be assessed as to the likelihood of damage to the cable, taking into account the storage facility or method of transport, and have battens fitted or re-fitted if considered appropriate.
- To protect against UV degradation, all cables in long-term storage (greater than 12 months) shall be shielded from direct sunlight or other UV sources by suitable coverings such as black plastic sheeting.
- A regular system of inspection and action shall be followed, paying particular attention to drums that have been stored for long periods (greater than 12 months). If a drum has deteriorated or been damaged, the cable shall be rewound onto a replacement drum, and the cable inspected for damage.

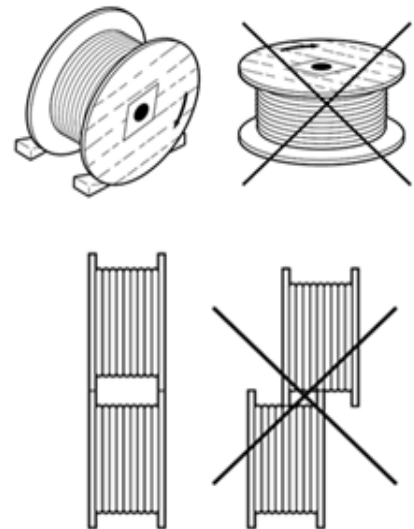



## 3 Handling and Transport of Cable Drums

### 3.1 Risk Assessment

A point-of-work risk assessment shall be carried out prior to handling or transport. The risk assessment shall take into account:

- The size of the cable and cable drums being handled or transported.
- The requirements of this chapter for handling and transporting cable drums.

### 3.2 Discharging New Cables

After manufacture, cables are subjected to insulation test voltages. Prior to handling, cables shall be discharged by short-circuiting all conductors together, then earthing.

### 3.3 Manual Handling

The Manual Handling Operations Regulations apply to a wide range of manual handling activities including lifting, lowering, pushing, pulling and carrying.

Wooden drums frequently have an arrow marked on their flanges to indicate both the direction that cable is to be wound on to them and also the direction in which the drum is to be rolled.

The following requirements shall be met whenever handling cable drums:

- Cable drums shall be rolled only for short distances over flat, solid ground in the direction indicated by the arrow on the flange having regard to:
  - The mass of the drum.
  - The method and direction of rolling.
  - The condition of floor/ground including slopes.
  - The risk assessment.
- **On no account shall a drum be rolled down an incline.**
- Particular care shall be taken when drums are full of cable.
- Particular care shall be taken with larger cable sizes.



**Table 4 Nominal Weight of Conductor (kg/m)**

CONDUCTOR >	3c 95mm	3c 185mm	3c 300mm	4c 95mm	4c 185mm	4c 300mm
LV Waveform Cable	2.13	4.04	5.36	2.63	4.76	6.5
11kV Triplex Cable	2.85	3.88	5.2	NA	NA	NA

### 3.4 Lifting

The following requirements shall be met whenever handling cable drums:

- Only fork-lift trucks or cranes of sufficient size and weight limit for the drums to be lifted shall be used.
- When lifting drums by crane, a spreader beam shall be used.
- The spreader beam shall be of the weight capacity and length specified by the manufacturer for the weight and width of drum. Any slings or hooks shall be of the correct weight capacity, as specified by the manufacturer, for the drum to be lifted.
- When lifting drums by fork lift trucks, the drums shall be upright, but at right angles to the forks, and the forks shall be longer than the width of the drum
- Advice shall be sought from the truck supplier before using specially adapted fork lift trucks (for example: spindle type lifting bars; booms; fork shoes; extensions).

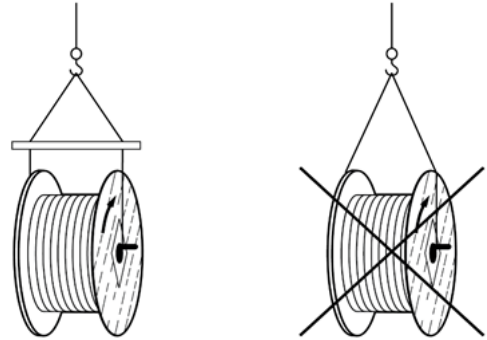

### 3.5 Unwinding and Rewinding

The following requirements shall be met whenever unwinding and rewinding cable drums:

- Unwinding and rewinding of cables shall be performed as shown with the drums mounted on A Frames.

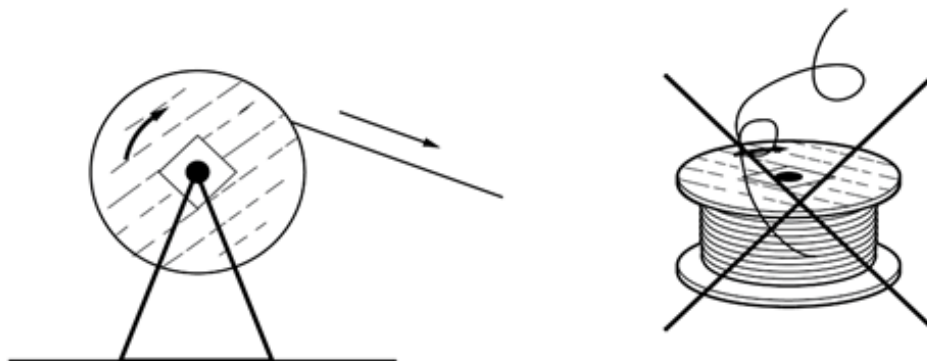

- If a cable is to be rewound on to a different drum, the drum selected shall be capable of carrying the weight of cable and have the appropriate drum barrel diameter.

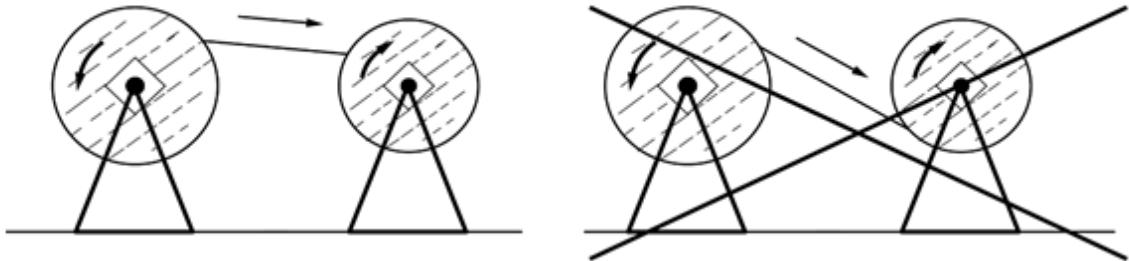

- The Minimum Barrel Diameter (MBD) shall be at least 20 times the measured overall diameter of the cable. Smaller MBDs shall only be used if recommended by the cable manufacturer.
- Repeated winding and excessive tension shall be avoided because it could damage the cable.
- Following cutting, all cable ends shall be sealed to prevent moisture ingress. (Pre-formed heat shrink or cold shrink end caps with a moisture seal are most suitable for this purpose. The use of tapes alone might not guarantee moisture tight sealing and shall be avoided.)
- Slack turns shall be tightened to prevent abrasion damage and trapped turns.

## 4 Transporting Cable Drums

An insulation test shall be carried out on the cable before loading the cable drum on to a trailer. Refer to CP319 for testing.

Refer to [Section 4.3](#) for guidance on loading a trailer and preparing for transport.

### 4.1 Storage and Handling at the Installation Site

The following requirements shall be met whenever storing and handling cable drums on site:

- If fitted, battens shall not be removed from drums until the cable is about to be installed.
- Battens shall be made safe (i.e. nails removed) and removed from the immediate area prior to installation.
- Tension limits for the cable shall not be exceeded.
- The cable shall not be bent within its minimum bending radius.
- Refer to ES 400E4 or ES 400E5 for more detail on the above, and for cable installation requirements.

### 4.2 Manual Handling of Cables

In addition to the requirements above, the following requirements shall be met whenever manual handling cable:

- Complete a risk assessment for pulling cables of the drum, pulling in, cutting, rolling and lifting.

- Determine the number of persons required for pulling cables of the drum, pulling in, cutting, rolling, and lifting operations.

#### 4.3 Procedure for Loading a Trailer and Preparing for Transport

- Connect trailer to towing vehicle using correct towing bolt and ensure that the towing bolt is locked in position.
- Ensure that the Bowden cable is securely attached to the towing hitch.
- Align the drum with the trailer ensuring that the cable can be run out from the top of the drum and to the rear of the trailer.
- Use a cable drum lever for turning the drum. (Refer to [Drawing I-430P1-M552-002](#)).
- Fit spindle through drum ensuring that the locating bolts go into the locating holes in the drum. (If there are no holes in the drum, screw bolts shall be used to locate the spindle.)
- Fit the securing ring to the spindle ensuring that it is the correct way around. (The bolts shall be away from the drum as shown in [Drawing I-430P1-M552-001](#).)
- Tighten securing bolts.
- Lower trailer legs and lock handles in line with the trailer.
- Winch the cable drum trailer forks down until they align with the cable drum spindle.
- Align cable drum spindle with forks on cable drum trailer and fit securing pins. Lock securing pins in position using `R' type lockpins.
- Raise cable drum using the trailer winch – do not over tighten the winch as this could cause distortion of the trailer. Fit securing pin and lock in position using `R' type lockpin.
- Fit drum brake to the drum spindle and trailer ensuring locating pins are locked in position.
- Tighten drum brake to lock the cable drum.
- Raise the trailer legs and lock in position, then release the trailer hand brake.
- Fit number plate and light board to rear of trailer ensuring that it is locked in position. Connect lighting plugs to trailer and towing vehicle and ensure all lights operate correctly.

## 5 Documents Referenced

DOCUMENTS REFERENCED	
ENWL Code of Practice 319	Applied HV Tests
ENWL Specification ES400E4	Specification for Installation, Commissioning and Repair of Solid Type Underground Cables Operating at LV, and 11kV and the Restoration of Excavated Areas
ENWL Specification ES400E5	Specification for Installation and Commissioning of Underground Cables Operating At 33kv and 132kv, and the Restoration of Excavated Areas

**Drawing I-430P1-M552-001**

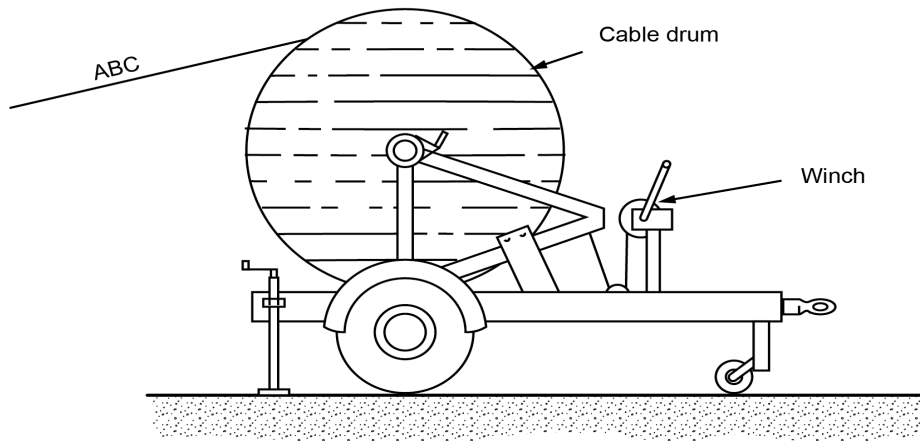

1. Check swl of trailer and drum weight.
2. Drum trailer should either be attached to vehicle or securely backstayed during running out operations.

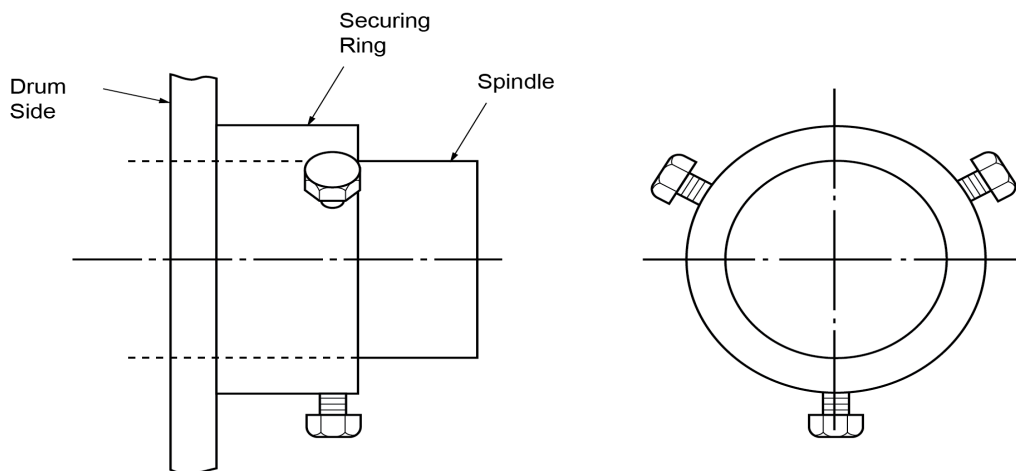

LOADING THE DRUM TRAILER

Change information for this issue  
N/A

Appears in  
CP430 Pt 1



I-430P1-M552-001 Iss 1 sht 1 of 1

Scale: nts Auth: DMT Date: 24/7/2014

**Drawing I-430P1-M552-002**

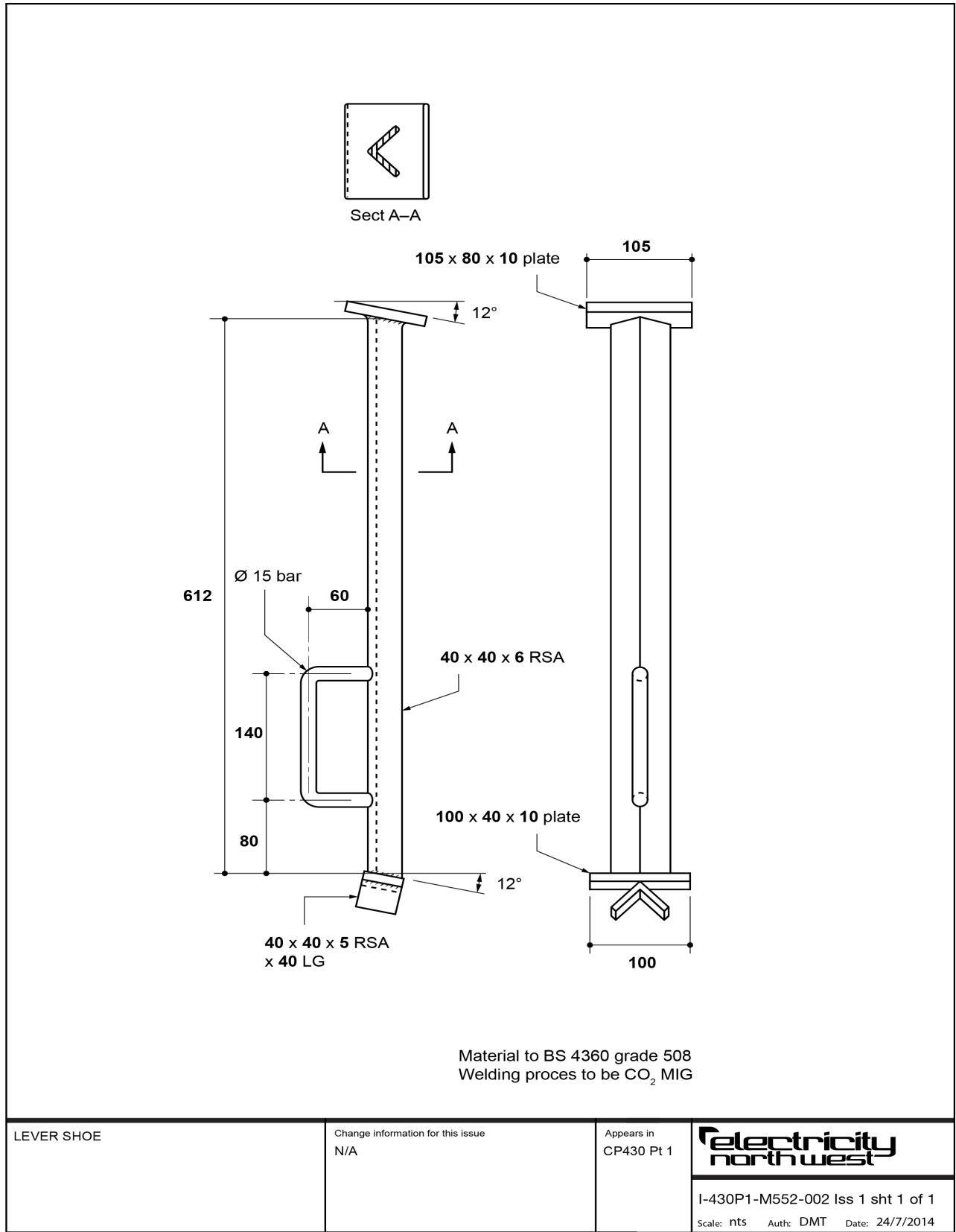

## Chapter 5 – Cable Bridges and Similar Structures

Features such as watercourses, railways and sunken roadways may obstruct cable routes and prevent the installation of cables by normal burial or by ducting. A cable bridge, or the attachment of the cables to an existing structure, may be proposed to overcome such obstacles.

A cable bridge may comprise any bridging structure to which cables are attached, externally. Alternatively, it may also comprise a bridging structure where the cables are totally enclosed within the structure, such as a steel box structure or a steel pipe. Bridges may be used to cross a range of geographic obstacles such as roads, railways, canals, rivers and smaller waterways, valleys or channels or even between buildings.

This Chapter describes:

- The means of installing cables across a span not exceeding 10m in length using a simple beam, pipe or portal frame bridge, all without intermediate supports.
- The means of attaching cables to another structure in order to negotiate an obstacle.
- Inspection and maintenance policy for these structures to be adopted to preserve the condition of the structure

These requirements shall be applied wherever a cable in the system voltage range Low Voltage – 132 kV is installed on a cable bridge of the type described or is attached to another structure.

If the size, shape or nature of the bridge or attachment falls outside the parameters described and the then professional advice shall be sought from a suitably qualified civil engineer.

### 1 Definitions

The following definitions apply throughout this chapter:

<b>Attachment</b>	shall mean the installation of an underground-type cable or cables on a structure not specifically placed to accommodate them.
<b>Cable Bridge</b>	shall mean a structure specifically installed to enable the installation of an underground-type cable or cables over an obstruction.
<b>ENWL</b>	Electricity North West Limited

### 2 Preparatory Work

#### 2.1 Applications

Cable bridges and attachments require a long-term commitment to maintenance and security. The decision to install a bridge or attachment shall be preceded, therefore, by careful consideration of whether an alternative underground solution is feasible.

Cable bridges and attachments shall not be used to cross the following types of obstacles:

- Motorways.
- Railways electrified by overhead catenaries.

Cable bridges and attachments shall not be used to support fluid-filled cables.

**NOTE:**

Excludes situations where, for example, a fluid-filled cable is installed in a leak proof pipe across a minor depression and assessment shows that the risk of polluting a watercourse is negligible.

## 2.2 Notices and Consents

Before work is started, the Engineer shall ensure that all necessary notices and consents are obtained and cleared, as required by Chapter 3, Clause 4.1 of this Code of Practice.

## 2.3 Functional Requirements

### 2.3.1 Introduction

The functional capability of the installed cables and the risks to which they are exposed may well be modified by installing them on a bridge or other structure. It is important that all these parameters are identified and evaluated as part of the design process prior to installation.

To allow the design work to proceed, therefore, the Engineer shall supply or otherwise agree the following items:

- A schedule of all the cables to be supported by the structure.
- The Technical Particulars relevant to each cable included in the schedule.
- The Primary, Secondary and Supplementary Requirements (as defined below) that the Design shall satisfy.

### 2.3.2 Primary Requirements

The Primary Requirements are:

- The continuous, cyclic and short circuit ratings for each power cable included in the schedule shall be maintained.
- The vertical and horizontal clearances that the structure as a whole provides shall be adequate.

### 2.3.3 Secondary Requirements

The Secondary Requirements shall be addressed as follows:

- Adequate dimensions in order to maintain the grouping or separation of circuits for purposes of operational security in the event of fire or any other destructive event.
- Adequate precautions to secure freedom from electro-magnetic interference, either between circuits or between a circuit and the supporting structure.
- Requirements for earthing and lightning protection.



- Statutory and other obligations for the protection and preservation of the environment.
- Relevant health and safety issues.
- Features such as retaining walls that are necessary to ensure the stability of the structure.
- Features required to protect the installation from interference or damage.
- Features to enable maintenance of the structure and the cables on it.
- Public acceptance issues, such as appearance.
- Special requirements relating to disposability at the end of operational life.

#### **2.3.4 Supplementary Requirements**

The Supplementary Requirements are those deemed by the Engineer to be reasonably necessary such as:

- The production of evidence to support calculated results.
- The method(s) of installation that may be employed.
- Particular requirements relating to the type and design of structure and the manner of attaching cables to it.
- The timing of the installation work.
- The division of responsibilities for activities to be carried out throughout the construction.
- The requirements for liaison with other bodies affected by the installation.
- Access to the site for installation, inspection, maintenance and disposal of the structure.
- Facilities and access to inspect and test materials.
- Facilities and access required for inspection and testing the installation either as a whole or in part.

## **2.4 Design Specification**

### **2.4.1 Standards to be Adopted**

As far as reasonably practical every aspect of the Design shall be in accordance with the relevant Standard.

Standards shall be called up in order of preference as follows:

- BS EN Standards.
- British Standards.
- Technical Specifications and other publications issued by Electricity Association Ltd.
- ENWL Standards.

### **2.4.2 General Requirements of Design Specification**

A Design Specification shall be prepared for the Approval of the Engineer.

The purpose of the Design Specification is to:

- Demonstrate that the Primary, Secondary and Supplementary Requirements will be satisfied.
- Identify any features that are critical to this achievement.
- Identify any significant operational, health, safety or environmental hazard that may arise during the life cycle of the installation.

The Design shall be appropriate to the situation. It may be thought practical to employ a Design in more than one situation, but care shall be exercised so that all the variables are taken into account at each location.

The Design Specification shall address the following features of the structure:

- Location.
- Subsoil.
- Foundations.
- Superstructure.
- Loading conditions.
- Cable installation.
- Earthing and lightning protection components.
- Anti-corrosion protection.
- Security and fire protection features.
- Maintenance.
- Disposal.

## 2.5 Location and Site Conditions

The location of the bridge shall be decided having regard to:

- The ease of access for both construction and maintenance.
- The existence of soil conditions suitable for foundations.
- The need for future inspection and maintenance.
- The security of the installation.
- The disposal of the bridge at the end of its working life.

### 2.5.1 Subsoil

The structure shall be stable in the longer term, and it should be appreciated that the subsoil, foundations and superstructure act together. The Design shall consider these three elements as an entity.

Characteristics of the subsoil that may contribute to instability are:

- Failure of the soil in shear which may cause plastic flow under the foundation.
- Settlement of the soil due to consolidation under the foundation, and in particular, differential settlement under the various parts of the foundations.

An overall appreciation of the conditions below the surface of the site is essential. Empirical solutions based on experience may be adequate for very small lightly loaded structures, but for all larger structures, a thorough factual investigation shall be made. This will always involve site investigation at or very close to the site of the

proposed foundations and may include laboratory examination of soil samples. The procedures are described in [Appendix A](#).

## 2.6 Foundations

The foundation is that part of the structure that transmits the weight of the structure and other forces and moments from the structure to the subsoil.

The foundation design shall have regard to:

- The safe bearing pressure of the subsoil.
- Subsoil expansion and shrinkage.
- Scouring adjacent to waterways.
- Balancing the load on the load-bearing stratum.

Foundation requirements for cable bridges of this type and size will usually be adequately met by a plain concrete block under each end of the superstructure. The procedures for designing simple foundations of this type are described in [Appendix B](#).

## 2.7 Loading Conditions of the Structure

Loading conditions shall be considered as follows:

- **Dead load:** The dead load refers to the cables on the bridge. The relative importance of the dead load increases with an increase in the span of the bridge. A proposal to attach a cable to another existing structure constitutes an increase in the dead load of that structure, the significance of which shall be evaluated.
- **Live load:** The live load refers to any mobile, variable load that the bridge carries. For cable bridges constructed in accordance with this Code, live loading is not permitted. Access to the bridge, when required, shall be by means of approved access equipment.
- **Wind force:** The wind force exerted on structures in this category is insignificant.
- **Aeolian and other vibration:** The frequency and magnitude of such vibrations are unlikely to be significant factors in the design of this class of structure.
- **Snow and ice loading:** Not regarded as significant.

## 2.8 Structural Components

Steel stock suitable for cable bridges is supplied in various standard sizes and weights. These are referred to as:

- Hot-rolled joists, channels, angles & T-bars (recognisable from the flanges, which have a characteristic tapered profile and are only available new in comparatively small sizes).
- Universal Beams (UB) and Universal Columns (UC) (have replaced the traditional rolled steel joist in all larger sizes and are recognisable by the squarer nature of the section detail: UBs are designed for

use as beams, having good resistance to bending in one direction, UCs are intended for use as columns, and have good stiffness in both directions).

- Hot-rolled circular hollow section (CHS), and rectangular hollow section (RHS): These are designed for use primarily as columns, for which their inherent good stiffness in both directions is an advantage.

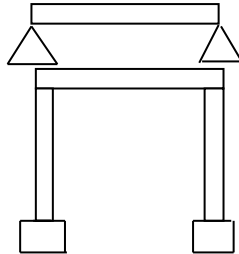

Figure 1

The use of second-hand steel stock, which is cheaply available, may be proposed. Caution is required, as the condition of both the structural member and the surface finish may be unsuitable for long-term installation without additional maintenance.

The use of steel pipes is deprecated, except for very light duty. They are not designed for structural use.

Cast iron pipes shall not be used. They have little structural strength when subject to bending stress and are prone to fracture on impact.

Second-hand gas pipes shall not be used. They may contain corrosive substances that are detrimental to cable oversheath materials.

Bridges shall be of the types shown in [Figure 1](#), according to application:

BASIC FORM	DUTY	TYPE OF STRUCTURE
Simple Beam	Spans up to 10m, light to medium loading	Universal beam, joist or channel
Portal Frame	Spans up to 10m, light to medium loading	
	Spans up to 30m, with heavy loading	Plate girder, with or without columns
	All spans, all loadings	Lattice girder, with or without columns

It is recognised that some interpretation is required of the loading criteria referred to above. The table is meant only as a guide to selecting a suitable type of structure before embarking on a detailed design process.

Information about the design and selection of structural members is given in [Appendix C](#).

## 2.9 Cable Installation

In designing the accommodation for the cables on the bridge or structure, the following points require evaluation:

- **Bending Radii:** The radius around which any cable is bent shall be as large as practical. The Minimum Bending Radius specified by the manufacturer is a value that should only be utilized as a last resort. No cable may be bent to any smaller radius than the specified Minimum Bending Radius.
- **Prevention of mechanical damage:** The Design shall have regard to risk of mechanical damage to cables implied by, for example, vandalism, children playing on or about the structure, cattle rubbing, vehicle impact and soil erosion.
- **Sun screening:** Cables are subject to a reduction in current rating if exposed to direct sunlight. Such exposure may also have, in the longer term, a detrimental effect on the plasticity of the oversheath material. Both these effects shall be mitigated by the inclusion of sun screening in the Design.
- **Spacing and grouping:** The Design shall not only incorporate the requirements specified for the separation of circuits as an aid to operational security, but also allow adequate heat dissipation from the cables.
- **Electromagnetic effects:** In situations incorporating single core cables care shall be taken to ensure no single cable or pair of cables is surrounded by a ferromagnetic loop.
- **Thermal effects:** Although thermal effects may be reduced by careful attention to detailed design as described above, some movement due to thermal expansion and contraction is inevitable. It should be appreciated that both the cables and the superstructure are subject to such movement.
- **Cleating:** All cables shall be securely cleated in position, but it is imperative that allowance is made for expansion and contraction. Thermal movement causes a thrust in the cable that, if the spacing of supports is too close, results in bodily movement through the supports until slack cable builds up in some convenient position such as a bend. Subsequent thermal movement is then concentrated in this short span, and the repeated flexing may lead to failure. Suitable support spacing for polymeric insulated cables are given in [Table A1](#), and the cables shall be arranged with sag of about 2% between the supports.
- For further reading and access to a more theoretical approach the reader is referred to Electrical Cables Handbook ,ed:Bungay & McAllister.

To preserve structural integrity, structural members may not be drilled in order to fix cleats. Such fixings shall be made using welded brackets or clips.

Information about the weight of cables in current use is given in [Table A2](#).

## 2.10 Earthing and Lightning Protection Components

In order to prevent undesirable transient voltages being impressed on the structure it shall be earthed locally by an electrode with a resistance to earth not exceeding 10 ohms.

If the cables installed on the structure are part of a solidly bonded system, they shall also be bonded to the local earth electrode.

If the cables are part of a specially bonded system steps shall be taken to ensure that the insulation value of the cable oversheath is preserved.

Facilities to test the earth electrode with the cable circuits live shall be installed where necessary.

The provision of lightning protection shall be considered in the case of portal frame structures and provided where necessary.

### 2.11 Anti-corrosion Protection

All ferrous metal components shall be effectively treated to inhibit the onset of corrosion. Precautions against electrolytic corrosion shall be taken as necessary at interfaces between dissimilar metals.

The anti-corrosion protection shall be of equivalent standard to that specified for overhead line steelwork in ENA TS 43- 96.

### 2.12 Security and Fire Protection Features

All reasonable precautions shall be taken to ensure the security of the installation and to prevent unauthorised access to the structure and the cables on it.

The fire hazard on the structure itself is considered to arise mainly from the activities of vandals. The extent of the precautions necessary shall have regard to the location of the structure and the environment. Structures located in High Risk areas (as defined in CP 420 Part 1 Appendix A) shall be protected to an appropriately higher degree.

For reasons of cost and spacing difficulties, the use of especially fire-retardant designs of cables shall be avoided unless exceptional operational requirements dictate the need.

Notices and nameplates shall be fitted and maintained according to the requirements of ES 356. An additional notice shall be fitted drawing attention to the fact that the bridge is not designed to support a live load.

No combustible materials shall be incorporated into the structure.

**NOTE:**

This excludes: materials used in the cables installed on the structure; notices and nameplates that may be faced with plastic materials; minor items such as bitumen paint used at the ground line.

Paint, as used for anti-corrosion protection, shall be of a suitable type to inhibit the spread of fire.

As far as reasonably practical the structure and the cables on it shall be effectively screened or separated from any source of fire that may originate adjacent to the structure.

Cables shall be screened and separated so that:

- The possibility of extensive damage by casual vandalism or malicious interference is minimized.

- In the event of a fire, the likelihood of cable outages outside the requirements of ER P2/5 are minimized.

### 2.13 Maintenance

The structure shall be designed for minimum maintenance.

Right of access to work on and about the structure shall be legally secure.

Procedures applicable for safe working shall be:

- Agreed with the owners and users of the land.
- Documented.
- Accessible to maintenance personnel.

### 2.14 Disposal

The design of the bridge and the installation method shall make reasonable provision for it to be eventually removed and the site reinstated.

As far as reasonably practical the design shall be free of all special requirements for disposal. Statements of any such requirements that are necessary shall be documented and retained.

## 3 Inspection and Maintenance Policy for Company Owned Cable Bridges

### 3.1 Introduction

Cable bridges owned and used by ENWL are located at a variety of fixed locations which may be owned by ENWL or by a third party. These sites require periodic inspection to ensure that all the bridge and all associated assets owned by ENWL are in a safe condition and fit for continued service with any defects found recorded so that appropriate remedial action can be taken.

### 3.2 Safety

All work shall be done in accordance with current Health and Safety legislation and the requirements of the ENWL Distribution Safety Rules where relevant.

A site risk assessment shall be completed before commencing work at every site.

### 3.3 Site and Structures

The following ENWL owned assets shall be subject to an inspection regime:

- Cable bridge
- Nameplates and Property Plates
- Anti-climbing devices
- Cables
- Cable attachment equipment

The following items outside the scope of this inspection regime.

- Substation compounds and security fences, which are covered by EPD301 Inspection and Maintenance of Electrical Plant and Substation Security
- Third party owned compounds and security fences
- Third party owned bridges or structures supporting cables

The frequency of inspection for site and structures shall be

- A basic safety and security inspection carried out once every 24 months. The content of the Safety and security inspection is currently as presented as the standard question set for cable bridges, which is available on the FDCS and FDM field data collections system associated with the Ellipse asset management system.
- A condition survey carried out once every 48 months. This shall include a detailed structural survey carried out by a structural surveyor together with basic safety and security inspection. The structural survey shall include an appropriately detailed survey of the structural frame of the bridge, which should be carried out in line with structural engineering principals and recommendations for bridge assets.

The inspection shall particularly address the question of structural stability, public safety and security of all the assets (bridge, cables ACDs, nameplates and property plates) and prevention of access by the public. The possible inter-dependence of adjacent and nearby structures should be considered as well as the serviceability of the whole or part of the structural elements.

Where a third party has equipment installed on an ENWL owned structure, any obvious faults with the third party's equipment noticed during the course of the inspection shall be recorded and the third party shall be notified. Cases of imminent danger or catastrophic collapse will be repaired by ENWL and charged to the third party concerned.

All ENWL cable bridges shall have their asset details and inspections recorded in the ENWL master asset management system, Ellipse.

Inspections shall be carried out using the question set available on FDCS hand held devices

Where birds are found to be in occupation and nesting on the structure, the inspection shall be postponed. Inspections shall wherever possible avoid the nesting season.

Once the inspection has been completed, a report shall be prepared detailing all necessary maintenance or repair work, following which action shall be taken, in an appropriate timescale up to but not exceeding 6 months from the date of inspection, to correct any defects found.

## 4 Documents Referenced

### DOCUMENTS REFERENCED



<b>Electric cables handbook</b>	Bungay & McAllister ISBN-10: 0849377102
<b>ENWL Code of Practice 420 Part 1</b>	Policy and Practice for Wood Pole Overhead Lines
<b>ENWL Specification ES 356</b>	Notices and nameplates
<b>Engineering Recommendation P 2/5</b>	Security of supply
<b>BS 5930</b>	Code of practice for site investigations
<b>ENA TS 43-96</b>	Fasteners and washers for wood pole overhead lines

## Appendix A– Investigation of Subsoil

### A.1 Aims

The aim of the site exploration, or sub-soil survey, is to provide data about the nature and disposition of the soil strata below the surface and to obtain, if necessary, soil samples from the different strata for laboratory examination. The results may have a profound influence on the design of both the foundations and the structure. It is important, therefore, to complete the investigation as early as practical in the project design phase after the Primary, Secondary and Supplementary Requirements have been determined.

If the proposed structure is light and simple it may be cheaper to check the site conditions with a trial pits and to use a high factor of safety in the design, rather than carry out an extensive survey. More extensive explorations are necessary, however, if the initial exploration indicates the sub-soil is likely to be unstable, or if a larger or more heavily loaded structure is to be built. This will usually require trial pits to be excavated or trial borings to be drilled.

Soil exploration shall be taken deep enough to include all strata likely to be affected by the loading. The foundation acts on a frustum below the pad, so exploration shall be made to a total depth of at least 1.5 times the total width of the longest side.

#### A.1.2 Properties of Subsoil

The principle property governing the bearing capacity of subsoil is the shear strength, which is mainly due to cohesion in the case of cohesive soils such as clay and on internal friction in the case of granular or non-cohesive soils such as sand and gravel.

Subsoil falls into three broad categories, as follows:

- Sands and gravels.
- Clays, silts or organic soils.
- Rock.

#### A.1.3 Procedure

All subsoil, particularly clays, yield to some extent under pressure, often over a very long time. Some judgment may be necessary, therefore, in determining the safe bearing pressure of the subsoil at a particular site. The extent of the exploration will depend on the size and type of structure, the nature of the site, and the availability of local geological data. BS5930 shall be used for complete reference.

The properties relevant to foundation design are the size and nature of the particles, and the moisture content, compressibility, permeability and shear strength of the soil.

A preliminary surface survey will often reveal useful data. In hilly country, for example, low-lying flat areas often indicate that water-deposited silt and clay may be found in varying thickness. Conversely, in flat country mounds of glacial moraine may be found. These may contain small pockets of sand or gravel or large stones in boulder clay, none of which provide reliable load-bearing conditions. Landslips of any kind indicate subsoil instability.

Indigenous vegetation may also provide useful data. Large deciduous trees indicate the presence of plentiful soil water, whereas conifers generally flourish in dry sandy conditions. The presence of reeds and rushes indicates very wet ground that is possibly subject to inundation. Existing excavations such as pits, road and railway cuttings, quarries and riverbeds may also provide useful preliminary information.

In many cases subsoil will comprise a mixture. Sands and gravels are often found mixed with clay, silt or organic soil. "Rock" may vary from solid hard rocks, weakly stratified rocks and broken or crushed rocks to artificial materials. On brown field sites, the presence of areas filled with tipped, un-graded material (which may be contaminated) should always be anticipated.

The subsoil strata may be examined by means of pits or boreholes. If suitable subsoil is not found by digging pits to a metre or two of depth, boreholes provide a more economical method of exploring the site. The number and disposition of the pits and boreholes will depend on the type of structure to be erected and the site conditions. There shall be a sufficient number, however, to provide an adequate picture of the subsoil conditions over the site and the depth shall include all strata likely to be affected to an appreciable extent by the proposed loading.

#### **A.1.3.1 Trail Pits**

Variability of conditions will be more apparent in a trial pit than in a borehole, and disturbed, undisturbed and hand cut samples can be taken without difficulty.

#### **A.1.3.2 Boreholes**

Boreholes are successful in self-supporting soils and are made by either hand- or power-operated augers, or hollow samplers.

The hand-operated auger makes use of a 50 – 100 mm diameter posthole borer and is likely to be successful in reasonably homogenous soft to firm clays, down to say 5 m depth. Stones and gravel will effectively stop them.

Power-operated borers are available in a variety of types and capacities covering any application likely to arise from building a cable bridge.

The output from an auger-bored borehole is, of course, a disturbed sample, and care is needed to identify the depth of changes in the constitution of the sub-soil.

If an undisturbed sample is considered essential, a shell auger, which has a hollow bit suitable for different types of soil, or a hollow sampler, may be used.

#### **A.1.3.3 In-situ Test**

The following tests may be helpful in obtaining data about the load-bearing characteristics of the subsoil in-situ. They are particularly useful where the nature of the subsoil makes it difficult to extract undisturbed samples for laboratory analysis. The information obtained, however, should always be regarded as supplementary to other evidence.

##### **A.1.3.3.1 Vane Test**

This test is suitable for soft or silt-bearing clay. It is applicable to boreholes not exceeding 30m in depth. The vane is pushed about 750 mm into the soil at the bottom of the borehole, and the force required to rotate the

vane is measured. This force is required to overcome the shear strength of the soil acting over the surface area of the cylinder enclosing the vane, from which the characteristic shear strength may be calculated.

#### A.1.3.3.2 Penetration Test

This test is suitable for sands and gravels. A 50 mm dia. bullet-shaped point is attached by means of extension rods to a 64 kg drop hammer over the borehole. Typically, the hammer is dropped 760 mm and the number of blows to produce 300 mm of penetration is recorded. The results are classified as follows:

Loose	< 10 blows;
Medium dense	10 – 30 blows;
Dense, or compact	>30 blows

#### A.1.3.3.3 Cone Penetrometer Test

Although this test is designed primarily to determine the bearing capacity of piles, it may be useful as an aid to rapid preliminary exploration. A force  $F_1$  is applied to the cone rod and is measured as the 36.5 mm dia. cone is pushed into the soil. The cone-retaining sleeve engages with a friction jacket and the force  $F_2$  required to insert the whole assembly is measured. The resulting friction may be calculated from  $(F_2 - F_1)$ .

#### A.1.3.3.4 Loading Test

This test is suitable for uniform non-cohesive soils (sand, gravel, crushed rock) and soft rock. It is not suitable for clays. Loads of appropriate increasing magnitude are applied to a steel plate laid at the proposed foundation level, and the rate and magnitude of settlement are measured. Initial settlement is rapid but of short duration. The load is increased incrementally, and settlement continues for a longer period with each increment. Eventually a point is reached when settlement continues indefinitely. The Ultimate Bearing Capacity of the subsoil is taken to be the value calculated from the maximum load, which can be applied before this occurs. The results should be treated with reserve, however, as for practical reasons the plate is usually smaller than the proposed foundation pad.

#### A.1.3.4 Subsoil Sampling for Laboratory Analysis

Laboratory analysis of the soil may be necessary if the size and weight of the proposed structure is of any great magnitude, or if subsoil conditions cannot be reliably established from site observation. The extraction of samples should be done correctly so that the results of the analysis are to be valid.

Samples for analysis of particle size and distribution may be dug loose from the bottom of a trial pit and stored in any convenient container.

Samples for measurement of compressive and shear strength are valueless if disturbed by the extraction process. The shear strength of some clay, for example, may reduce to one half or less of the in-situ value of the sample is disturbed or re-moulded. A proprietary tool, such as a shell auger or an open drive sampler is required.

A suitable sample of cohesive clay soil may be obtained provided the tool is used with care, and the ends are promptly capped to preserve the moisture content. The extraction of samples of dry non-cohesive sands and gravels is not usually a practical proposition, and reliance should be placed on in-situ tests for such types. For

moist and saturated situations, however, suitable samples may be obtained with the aid of a compressed air sampler. Sample cores of rock may be obtained with the use of a hollow rotary drill bit, but it should be noted that larger diameter samples are required for relatively soft rock compared to the size needed for harder varieties.

The values in [Table A3](#) shall be used as guidelines, but if there is any doubt professional, advice shall be obtained.

## Appendix B– Design of Simple Plain Concrete Foundations

### B.1 Introduction

The following paragraphs will enable a simple plain concrete foundation to be designed. If such a foundation is considered inadequate in particular circumstances, for example, in poor subsoil conditions or where the possibility of subsidence exists, professional advice shall be obtained.

#### B.1.1 Design Fundamentals

##### B.1.1.1 Consolidation Settlement

Plain concrete foundations take the form of a block or pier of concrete having a direct bearing in the soil stratum selected for the purpose. The principle factor governing the bearing area of the foundation is the permissible pressure on the soil ([Appendix A](#)).

It should be appreciated, however, that even in apparently homogeneous soils some settlement will occur. This arises because the soil is compressible, either as a single layer, or as multiple layers. Experience indicates that the compression process is effective down to about three times the foundation width. It is possible to estimate the likely amount of compression from knowledge of the volume compressibility of the soil, as determined by laboratory analysis, thus:

$$\text{Volume compressibility: } m_v = \frac{1}{h} * \frac{dh}{dp}$$

where:  $h$  = thickness of compressibility specimen

$dh$  = change in thickness due to change in pressure  $dp$ .

It is also important to appreciate that the settlement may not be uniform across the whole under-surface of the foundation block. The general experience is that the centre settles to a greater extent than the edges. This differential settlement can cause the foundation block to tilt, hence causing distortion of the structure. In the case of a bridge, it is of course possible for there to be differential settlement between the two supports.

Arising from the foregoing, it should be anticipated that, if the sub-soil were loaded to the values given above, settlement would occur over time of the order of 25 mm. This may seem insignificant, but it is, in fact, enough to place significant strain on the structure. Hence, all structures of this nature should be robust and substantially founded, even though the imposed loads may be only moderate.

#### B.1.2 Foundation Design

The foundation blocks are assumed to spread the load to the subsoil by dispersion at an angle of  $> 45^\circ$  to the horizontal. For this to be valid it is important that the load is applied concentrically so that there is no overturning moment applied to the foundation block.

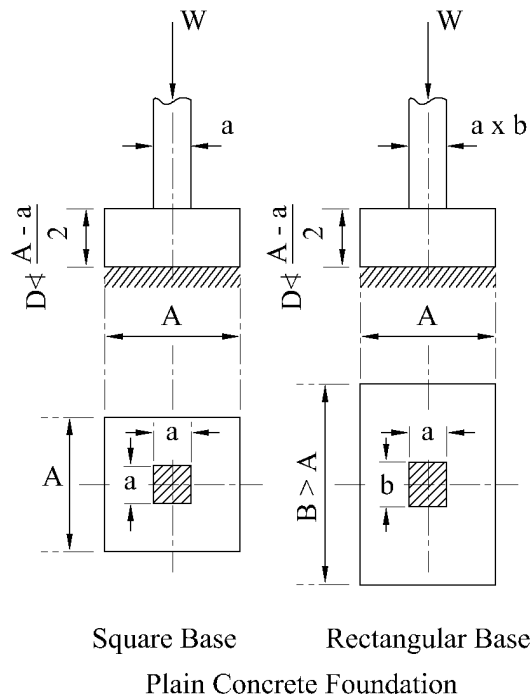

**Figure B.1**

Referring to Fig B.1:

A square block of side  $A$  in which  $A = \sqrt{\frac{W}{p}}$  is the most economical shape,

where  $W$  is the load imposed on the base plus the weight of the base and any overburden, and  $p$  is the safe bearing pressure to which the subsoil can be subjected.

The thickness  $d$  of the base should not be less than  $\frac{(A-a)}{\sqrt{2}}$  where  $a$  is the length of the side of the stanchion or beam supported.

If the installation of a square block of concrete is impractical, a rectangular block of sides  $A$  and  $B$  may be used, in which case:

If  $B > A$ , the dimensions shall be such that  $ABp > W$ ,

and  $d > \frac{B-b}{2}$  where  $b$  is the length of side, parallel to side  $B$ , of the stanchion or beam supported.

## Appendix C – Application of Structural Loads

### C.1 Structural Steel Design

#### C.1.1 Grades of Steel

There are three grades of steel in common use for structures: mild steel (grade 43), and high strength (grades 50 & 55). Grade 43 mild steel is suitable for cable bridges.

#### C.1.2 Hot Rolled Sections

There are three types of hot-rolled sections; rolled steel joists (RSJ), universal beams and columns (UB), (UC), and hollow sections, both circular and rectangular.

##### C.1.2.1 Rolled Steel Joists (RSJ)

Larger sizes of RSJ were discontinued in the 1950's in favour of Universal Beams and Universal Columns, but smaller sizes were retained. Joists, channels, angles and T-bars are all available, and may be recognised by the characteristic tapered flanges.

##### C.1.2.2 Universal Beam (UB) and Universal Column (UC)

These are much squarer in section than the equivalent RSJ. A UB has good resistance to bending in one direction, and a UC has good stiffness in two directions.

##### C.1.2.3 Hollow Sections

Circular and rectangular hollow sections are ideally suited for use as compression members, as they exhibit good stiffness against bending in all directions. In structural terms, a hollow section is more efficient than a UC, but it is comparatively expensive.

### C.1.3 Sizing of Beams

#### C.1.3.1 Variables in Specified Sizes

The specified sizes are based on the nominal or serial sizes, and within each size, there may be a range of weights because of different thickness of flanges and webs. It is normal to specify a steel section by the nominal or serial sizes and by the weight/metre length. For example, a serial size of 254 mm x 146 mm is available in three different grades, as follows:

UB 254 x 146 x 43 kg,

UB 254 x 146 x 37 kg,

UB 254 x 146 x 31 kg.

A similar approach will be found with hollow sections, but in those cases, the external dimensions are kept constant.

#### C.1.3.2 Need for Torsional and Lateral Restraint

A beam is comparatively slender in relation to the length, and it may become unstable when loaded unless adequate torsional and lateral restraints are provided.



### C.1.3.3 Torsional Restraint

The slenderness is a function of the stiffness, and the slenderer the compression (i.e. top) flange, the weaker the beam will be. Thus, when the load is increased the top flange will twist and eventually will buckle. This may cause the beam to fail, even though the stress in the beam at the point of failure may be considerably below the value applicable if the top flange is restrained from buckling. In such circumstances, the beam is assigned an “effective length” that may or may not be the same as the actual length.

### C.1.3.4 Example

Consider a simply supported beam that is built into a foundation block at each end. This has torsional restraint, and:

Effective length  $l = \text{span}$

If the ends are not so restrained, then typically:

Effective length  $l = \text{span} \times 1.2$

For this reason, a cable bridge beam shall always be adequately provided with torsional stiffness by firmly anchoring the beam at both ends.

### C.1.3.5 Lateral Restraint

The effectiveness of a simply supported beam may be optimised by effective lateral support of the compression flange. Clearly this may present practical difficulties with a single beam in this application, and it may be advantageous to employ two beams joined side-by-side by welded straps on longer spans, or for heavier duty. This approach has the added advantage that the straps provide a place from which to hang the cables without interfering with the structural members.

### C.1.3.6 Deflection

A safe side rule is to limit the deflection to  $1/360^{\text{th}}$  of the span. The load that produces this deflection is called the Deflection Load ( $W_D$ ) and is the safe load that the beam will carry based on the deflection limit, thus:

$$D_{\max} = \frac{5}{384} * \frac{W_D L^2}{EI}$$

where:  $D_{\max}$  = Maximum deflection at centre of beam

$W_D$  = Distributed dead load

$L$  = Length of span

$E$  = Young's Modulus =  $200 \times 10^9 \text{ N/m}^2$

$I$  = Moment of area = (view tables)

Hence,  $I$  may be determined, and a suitable beam size selected from the tables.

**NOTE: The appearance of the beam in situ can be much improved by pre-stressing it into a slight arch to match or slightly exceed the design deflection. This will then avoid the inevitable sag that appears when the beam is loaded.)**

### C.1.3.7 Rule of Thumb

A convenient rule of thumb exists for short, simple beams carrying building loads. This rule has a long history of application. It should not be used for spans longer than about 4 m, and it should be recognised that, unless the weight of cables is considerable, the resulting choice of beam will probably be over-designed as the weight of the cables is unlikely to approach the value that would be permissible as a floor loading.

The rule is:

The depth of beam required:  $D = \frac{l}{18}$

Where  $D$  = depth of beam required

And  $l$  = length of the torsional restrained span

(It is customary to increase the denominator to a value of 20, i.e. increase the permissible span, if the load is nominal. As stated above, even this denominator will indicate a much larger beam size than is necessary for many cable bridge applications, and it will be found more economical to calculate the beam size from first principles)

### C.1.3.8 Safe Loading for Beams, Simply Supported

Cable bridges shall normally comprise two parallel beams, and a safety factor of two shall be applied. Reference tables are given below for many typical sizes of beams in sizes likely to be useful in this application.

To choose an appropriate size of beam, proceed by following this example:

Consider a simply supported universal beam bridge comprising two parallel beams spanning 10 m and having adequate torsional restraint at each end, and adequate lateral restraint of the top flange. Let the uniform load be 1000 kg. (1 kg force = 9.81 N; therefore 1000 kg force = 9.81 kN, (say  $10^4$  N.)

We know 
$$D_{\max} = \frac{5}{384} * \frac{W_D L^2}{EI}$$

Where:  $D_{\max}$  = Maximum deflection at centre of beam = 10/360 m

$W_D$  = Distributed dead load =  $10^4$  N

$L$  = 10 m Length of span

$E$  = Young's Modulus =  $200 \times 10^9$  N/m<sup>2</sup>

$I$  = Moment of area = (view Table 4)

From this  $I = 2210$  cm<sup>4</sup> (note units)

Hence: beam size = 203 mm x 133 mm x 25 kg

If two beams are employed the safety factor > 2.0

#### C.1.4 Columns

The ability of a column to support a beam is determined not only by the cross-section, but also by the buckling load. The theoretical concept is that the influence of the buckling load reduces the effective height to which a column of a particular section may be extended when supporting a designated load. The effect is further influenced by the manner in which the top and bottom fastenings are made. If they are both stiff the effective length is half the actual length; if the top fastening is pivoted the structure is less rigid and hence, effective length is somewhat greater. For the small lightly loaded structures that are considered here, however, some approximations may be employed to remove the need for calculation. The graph (taken from exemplary data) shows the capability of various sections to support a load. It may be deduced, that given the dimensions and supported weights of a small cable bridge structure which will have two columns at each end of the beam, that only comparatively small sections are required.

It is necessary, however, to stiffen the structure by, for example:

- Welding the columns to a common base plate for attachment to the foundation blocks.
- Welding spacers between the columns.
- Welding the corner joints at the top of the columns.
- Welding corner plates or fillets on the corner joints.

**Table A1 – Spacing of Supports for Polymeric – Insulated Cables**

OVERALL CABLE DIAMETER (MM)	SOLID ALUMINIUM CONDUCTOR		STRANDED COPPER CONDUCTOR	
	HORIZONTAL SPACING (MM)	VERTICAL SPACING (MM)	HORIZONTAL SPACING (MM)	VERTICAL SPACING (MM)
<15	-	-	350	450
15 – 20	1200	550	400	550
20 – 40	2000	600	450	600
40 – 60	3000	900	700	900
>60	4000	1300	1100	1300

**Table A2 – Typical Cable Weights and Overall Dimensions**

VOLTAGE GROUP	CABLE TYPE	PHASE CONDUCTOR SIZE & MATERIAL	MASS	APPROXIMATE OVERALL DIAMETER
		(mm <sup>2</sup> ) (Cu) or (Al)	(kg/m)	(mm)
Low Voltage	1-ph CNE service cable	4 Cu	0.14	8
		35 Al	0.4	13
	1-ph SCNE service cable	4 Cu	0.17	9.5
		35 Al	0.5	16
	3-ph CNE service cable	25 Al	0.6	21
	3-ph SCNE service cable	25 Al	0.73	25
	Waveform (3core)	95 Al	3.2	33
		185 Al	4.5	45
		300 Al	5.4	55
	Waveform (4core)	95 Al	2.6	42
		185 Al	4.7	55
		300 Al	6.5	65
11 kV	Triplex	95 Al	2.9	60
		185 Al	3.93	70
		300 Al	5.14	78
		300 Cu	11.02	82
		400 Al		90
		400 Cu	13.56	90
33 kV	Triplex or 3 single cores laid in Trefoil	150 Cu	8.332	88
		185 Cu	9.482	92
		240 Cu	11.322	98
		300 Cu	13.203	102
		400 Cu	15.896	110
132 kV	Single core laid in trefoil	Details to be obtained from cable manufacturer		

**Table A3 – Typical Safe Bearing Pressures of Sub-Soils**

TYPE OF SUB SOIL			APPROXIMATE SAFE BEARING PRESSURE (TONNE/M <sup>2</sup> )	
			DRY	WET
Sand	Compacted dry	Well graded	40 – 60	Reduce to 50% of stated values if saturated
		Uniform	20 – 40	
	Loose	Well graded	20 - 40	
		Uniform	10 - 20	
Gravel	Compacted	Clean	40 – 70	
		Sandy	40 – 60	
	Loose	Clean	<30	
		Sandy	20 – 40	
Clay	Very stiff (boulder) and hard shale		30 - 60	Expect long term settlement due to shrinkage and/or permanent compaction under load
	Stiff and stiff sandy		15 - 30	
	Firm and firm sandy		8– 16	
	Soft		< 8	
Silts and organic soils	All types		<8	Unreliable for load bearing purposes
Rock	Solid hard		130	Bearing pressures depend on the degree of consolidation and should be determined by test or from professional advice
	Weakly stratified		50 - 100	
	Broken or crushed			
	Filling			

**Table A4 – Structural Steelwork Data – Universal Beams**

DESIGNATION		DEPTH OF SECTION <i>D</i>	WIDTH OF SECTION <i>B</i>	THICKNESS OF SECTION		AREA OF SECTION <i>A</i>	MOMENT OF INERTIA <i>I</i>
Serial size	Mass			Web <i>t</i>	Flange <i>T</i>		
mm	kg/m	mm	mm	mm	mm	cm <sup>2</sup>	cm <sup>4</sup>
<b>305 x 165</b>	54	310.9	166.8	7.7	13.7	68.4	11710
	46	307.1	165.7	6.7	11.8	58.9	9948
	40	303.8	165.1	6.1	10.2	51.5	8523
<b>305 x 127</b>	48	310.4	125.2	8.9	14.0	60.8	9504
	42	306.6	124.3	8.0	12.1	53.2	8143
	37	303.8	123.5	7.2	10.7	47.5	7162
<b>305 x 102</b>	33	312.7	102.4	6.6	10.8	41.8	6487
	28	308.9	101.9	6.1	8.9	36.3	5421
	25	304.8	101.6	5.8	6.8	31.4	4387
<b>254 x 146</b>	43	259.6	147.3	7.3	12.7	55.1	6558
	37	256.0	146.4	6.4	10.9	47.5	5556
	31	251.5	146.1	6.1	8.6	40.0	4439
<b>254 x 102</b>	28	260.4	102.1	6.4	10.0	36.2	4008
	25	257.0	101.9	6.1	8.4	32.2	3408
	22	254.0	101.6	5.8	6.8	28.4	2867
<b>203 x 133</b>	30	206.8	133.8	6.3	9.6	38.0	2887
	25	203.2	133.4	5.8	7.8	32.3	2356

**Table A5 - Structural Steelwork Data – Joists (RSJ)**

DESIGNATION		DEPTH OF SECTION	WIDTH OF SECTION	THICKNESS OF SECTION		AREA OF SECTION	MOMENT OF INERTIA
Serial size	Mass	<i>D</i>	<i>B</i>	Web <i>t</i>	Flange <i>T</i>		
mm	kg/m	mm	mm	mm	mm	cm <sup>2</sup>	cm <sup>4</sup>
<b>203 x 152</b>	52.09	203.2	152.4	8.9	16.5	66.4	4789.0
<b>203 x 102</b>	25.33	203.2	101.6	5.8	10.4	32.3	2294.0
<b>178 x 102</b>	21.54	117.8	101.6	5.3	9.0	27.4	1519.0
<b>152 x 127</b>	37.2	152.4	127.0	10.4	13.2	47.5	1818.0
<b>152 x 89</b>	17.09	152.4	88.9	4.9	8.3	21.8	881.1
<b>152 x 76</b>	17.86	152.4	76.2	5.8	9.6	22.8	873.7
<b>127 x 114</b>	29.76	127.0	114.3	10.2	11.5	37.3	979.0
<b>127 x 114</b>	26.79	127.0	114.3	7.4	11.4	34.1	944.8
<b>127 x 76</b>	16.37	127.0	76.2	5.6	9.6	21.0	569.4
<b>127 x 76</b>	13.36	127.0	76.2	4.5	7.6	17.0	475.9
<b>114 x 114</b>	26.79	114.3	114.3	9.5	10.7	34.4	735.4
<b>102 x 102</b>	23.07	101.6	101.6	9.5	10.3	29.4	486.1
<b>102 x 64</b>	9.65	101.6	63.5	4.1	6.6	12.3	217.6
<b>102 x 64</b>	7.44	101.6	44.4	4.3	6.1	9.5	152.3

**Table A6 – Structural Steelwork Data – Channel**

DESIGNATION		DEPTH OF SECTION	WIDTH OF SECTION	THICKNESS OF SECTION		AREA OF SECTION	MOMENT OF INERTIA
SERIAL SIZE	MASS	<i>D</i>	<i>B</i>	WEB <i>T</i>	FLANGE <i>T</i>		
mm	kg/m	mm	mm	mm	mm	cm <sup>2</sup>	cm <sup>4</sup>
<b>254 x 89</b>	35.74	254.0	88.9	9.1	13.6	45.52	4448.0
<b>254 x 76</b>	28.29	254.0	76.2	8.1	10.9	36.03	3367.0
<b>229 x 89</b>	32.76	228.6	88.9	8.6	13.3	41.73	3387.0
<b>229 x 76</b>	26.06	228.6	76.2	7.6	11.2	33.20	2610.0
<b>203 x 89</b>	29.78	203.2	88.9	8.1	12.9	37.94	2491.0
<b>203 x 76</b>	23.82	203.2	76.2	7.1	11.2	30.34	1950.0
<b>178 x 89</b>	26.81	117.8	88.9	7.6	12.3	34.15	1753.0
<b>178 x 76</b>	20.84	117.8	76.2	6.6	10.3	26.54	1337.0
<b>152 x 89</b>	23.84	152.4	88.9	7.1	11.6	30.36	1166.0
<b>152 x 76</b>	17.88	152.4	76.2	6.4	9.0	22.77	851.5
<b>127 x 64</b>	14.90	127.0	63.5	6.4	9.2	18.98	482.5
<b>102 x 51</b>	10.42	101.6	50.8	6.1	7.6	13.28	207.7
<b>76 x 38</b>	6.70	76.2	38.1	5.1	6.8	8.53	74.1



**Graph A1 – Loading Data for 3 Metre Column**

Mild steel  
(3m high)  
Rectangular hollow  
sections

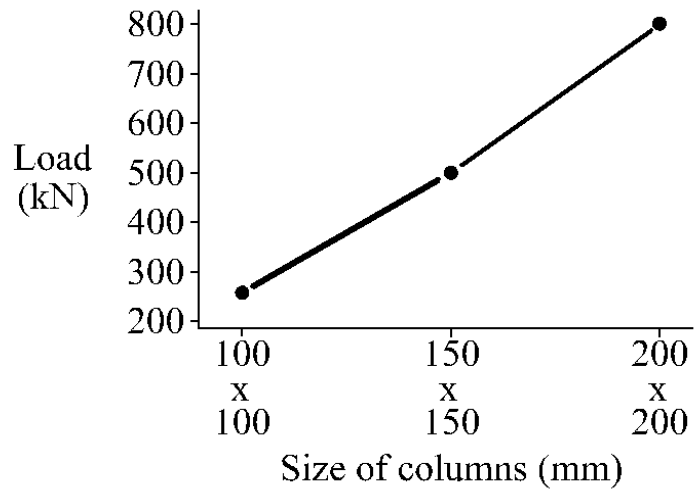
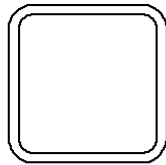

**Graph A2 – Height / Section Data for a Loaded Column**

Mild steel  
(load 260 kN)  
Rectangular hollow  
sections

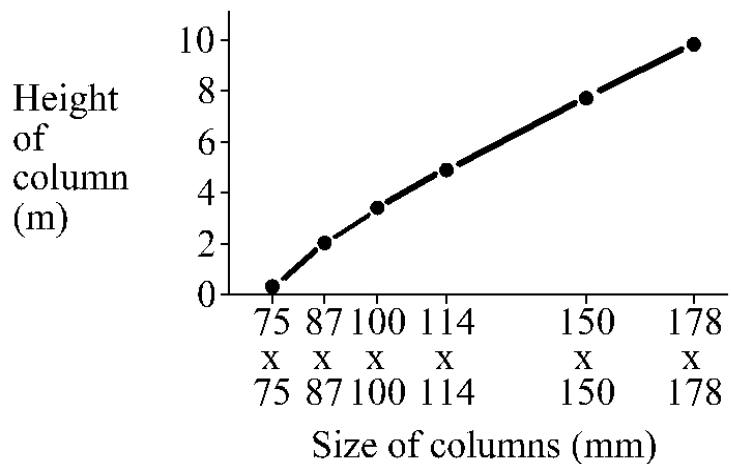
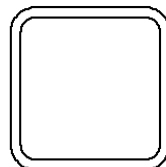

## Chapter 6 – Shallow Cables

This chapter covers the potential scenarios where parts of a proposed cable route cannot achieve the standard specified minimum laying depth of cover due to physical obstructions or other technical challenges.

This is typically for cables that are to be laid on over-bridge footways where there is limited depth for buried services but can also be where other obstructions need to be crossed which will restrict the depth of cover for cables.

### 1 Definitions

<b>Depth of Cover</b>	The vertical measurement between the crown of the buried cable or duct (or the uppermost group of cable/ducts) and the normal ground surface level
<b>GIS</b>	Geographical Information System
<b>ENWL</b>	Electricity North West Limited
<b>ESQCR</b>	Electricity Safety, Quality and Continuity Regulations
<b>Designer</b>	Organisation or individual responsible for designing all aspects of the cable route.
<b>Shallow Cables</b>	Any part of an underground cable route where the depth of cover will be less than the minimum values in the Specification.
<b>Specification</b>	The minimum depth of cover and use of protective devices as specified in ENWL specification documents ES400E4 and ES400E5.
<b>Trief® Kerbstone</b>	A high containment kerbstone profile  (Trief is a brand name for a design of high containment kerb profile - the design is licensed by a number of manufacturers).

### 2 Introduction

ENWL Specifications provide the minimum laying depth of cover and protective devices required at any point on the route for all new cable circuits being installed. These Specifications have been derived to ensure our obligations are met under Regulation 14 of the ESQCR, as follows:

#### 14 - Excavations and depth of underground cables

(1) Every underground cable shall be kept at such depth or be otherwise protected so as to avoid, so far as is **reasonably practicable**<sup>See Note 1</sup>, any damage or danger by reason of such uses of the land which can be reasonably expected.

(2) In addition to satisfying the requirements of paragraph (1), an underground cable containing conductors not connected with earth shall be protected, marked or otherwise indicated so as to ensure, so far as is reasonably practicable, that any person excavating the land above the cable will be given sufficient warning of its presence.

(3) The protection, marking or indication required by paragraph (2) shall be made by placing the cable in a pipe or duct or by overlaying the cable at a suitable distance with protective tiles or warning tape or by the provision of such other protective or warning device, mark or indication, or by a suitable combination of such measures, as will be likely to provide an appropriate warning.

**NOTE<sup>1</sup>**

In the context of the ESQCR, the term “**reasonably practical**” requires that the duty holders shall undertake an assessment to compare the time, complexity, and expense of eliminating or reducing any risk to an acceptable level.

Essentially, the greater the degree of that risk, the less weight can be given to the consideration of cost measures in preventing that risk.

Any proposal to use Shallow Cables in any route shall be only considered as a last resort when all other options to achieve the necessary depth of cover along the route according to the Specification have been demonstrated by the Designer to be not **reasonably practical**.

The route length of any Shallow Cables shall be kept to the absolute minimum necessary.

Shallow Cables increase the risks of intentional or accidental interference, danger, or interruption of supply and therefore the introduction of additional measures and controls are necessary to ensure this increased risk can be eliminated or reduced to an acceptable level.

Examples of the risks for Shallow Cables include penetration of cables from concrete cutting tools e.g., road/floor saws, jackhammers or damage incurred from mechanical compactors or high speed vehicular impacts. Long term effects due to sustained vibration caused by heavy traffic may also need to be considered.

As a general rule, even with any additional measures and controls, the minimum depth of cover shall never be less than 300mm for all cable types. The overriding aim shall always be to achieve the maximum possible depth to meet the Specification, then use any additional measures as appropriate to reduce risk of interference, danger or interruption of supply.

It is incumbent on the Designer to fully demonstrate a process has been undertaken to show that any requirement for Shallow Cables on a proposed route is unavoidable, as all alternatives are not reasonably practical **AND** to carry out a fully detailed risk assessment identifying all the foreseeable risks during all stages of the circuit lifetime and how they will be reduced to an acceptable level by using additional appropriate measures and controls.

### 3 Process

This applies to any cable route where the need for Shallow Cables is required, irrespective of the route length of the Shallow Cable portion.

The Designer shall, at their own expense, provide the following information as part of their design approval for consideration by ENWL.

- A full justification why the Shallow Cable route(s) is the only reasonably practical option that can be used. This shall include full details of all alternative routes and the reasons why they are considered to be not suitable.

- All background information on the restrictions to achieving the normal depth of cover in the proposed Shallow Cable route including any remedies which have been ruled out as not reasonably practical.
- Details of the proposed additional measures to be used on the Shallow Cable portion of the route which will eliminate or reduce risks to an acceptable level. If there is more than one potential arrangement with different merits/disadvantages, then these details shall be provided including the preferred option and justification for that choice. Examples of additional measures are shown in [Section 4](#).
- A record of any specific approvals or sanctions by third parties who may operate or own particular assets used or affected in the portion of route containing Shallow Cables , e.g. bridge owners, councils or other utilities.
- A full Risk Assessment shall be made which includes all the foreseeable risks of interference, danger or interruption of supply which may occur during every phase of the lifetime of the route , together with details of what additional measures will be used and how they will remove or reduce the likelihood and severity of the risk to an acceptable low level.  
Examples of the layout of this Risk Assessment is shown in [Section 5](#)

If the Designers Risk Assessment does not demonstrate how the risks are eliminated or reduced to an acceptable low level, then the submission shall not be approved.

Where there is any doubt or ambiguity in a proposal, then the decision of the ENWL Circuits Policy Manager will be final in determining if it is acceptable.

## 4 Additional Measures

The following are some examples of additional measures that can be used to remove or reduce the risks associated with Shallow Cables. Dependent upon the specific risks, a combination of these and other measures may be used.

Further information can also be found in ENA Engineering Recommendation C98.

### 4.1 Marking on GIS records

In all cases, upon completion of any Shallow Cable route, the relevant part of a route shall be clearly marked up on the GIS records to indicate SHALLOW CABLE. Refer to CP012, Section 8 for items that should be identified that could give rise to dangerous situations or system problems if account is not taken of their abnormal features.

### 4.2 Local Identification and Warning

To ensure that parties who pass nearby or may be involved in nearby works are aware of the presence of Shallow Cables, local signage such as surface marker blocks, marker posts or other general notices should be considered if practical and relevant. The signage shall be used at the start, middle and end of the Shallow Cables route, or at regular intervals along the route if required.

Signs shall be in accordance with ES356.

### 4.3 Build-up of depth of cover

Where the depth of cover required in the Specification cannot be achieved, then, if practicable, consideration should be given to raising the normal surface level height to increase depth of cover to a more acceptable level in the area immediately above the cable.

For cables laid in kerbside of bridge footways, building up using Trief® or equivalent high containment kerb stones in combination with other mechanical protection shall be considered. However, this arrangement shall not create potentially harmful situations which increases risk of injury from vehicular collisions and should only be proposed where there is full agreement from the relevant council or highways authority.

See [Figure 1](#) and [Figure 2](#) for examples of how these can be used.

For single core cables normally laid in a triplex formation, consideration shall be given to laying single cores in flat formation to increase available depth of cover. However, the increased width and effect on current ratings should be considered.

### 4.4 Enhanced Mechanical Protection measures

Mechanical protection measures provide a final level of protection against persons who have failed to identify the presence of the cables or from accidental impacts caused by vehicles.

Increased protection against impact and penetration can be achieved using following examples. Depending upon the voltage level, deviation from the normal depth of cover and the overall risk, a combination of these or other solutions may be adopted.

#### 4.4.1 High Strength Ducts

For minor deviations in depth of cover, upgrading to High Strength grade PVC (e.g. 1500N rated) or SDR (PE) ducting can be used in place of standard PVC versions. This can be supplemented with additional protective tiles or steel plates laid above the ducts.

#### 4.4.2 Steel Sleeves

A Steel sleeve will provide a higher level of physical protection for Shallow Cables over using PVC or PE ducts on their own.

To remove risk of abrasion damage to cable sheaths during installation and in general operation, the steel sleeves shall be lined with a smooth walled PVC duct of the size normally used with the cable type and size. The steel duct shall have a minimum wall thickness of 5mm and be of adequate diameter to allow the PVC ducts to be installed without damage. The PVC ducts shall protrude from all ends of the Steel sleeves by at least 10mm to prevent any scraping damage from edges of the steel material. Steel sleeves shall not be used alone for containing any cable.

It is permitted to install a 3-core cable or 3 x single core cables into a steel sleeve. Each cable circuit should be installed into a single steel duct; single core cables should not be laid in individual steel sleeves.

#### 4.4.3 Reinforced Composite Troughs or Ducts

Composite materials of fibre cement reinforced by mechanically bonded steel sheeting, can be used as an alternative to steel ducts.

#### 4.4.4 Steel Plates

Steel plates may be used in conjunction with cable ducts to provide additional physical protection of Shallow Cables.

The thickness of the steel plate should be at least 5mm and the plate should overlap the cable or duct by 100 mm on all sides.

Cable Warning tapes or protective tiles shall be fitted above the steel plates to indicate the presence of cables.

#### 4.4.5 Concrete Slabs or Arches

Suitably constructed concrete slabs or arches can be fitted for mechanical protection of ducted cables. Concrete slabs or arches should be sufficiently thick for weight bearing purposes.

### 4.5 Restrictions in use or access

Where practicable, vehicular and foot traffic should be removed or reduced in the immediate vicinity of the Shallow Cables by use of barriers and fencing. If there is a risk of vehicular traffic damaging the ground through accidental strikes, then consideration to implementing traffic calming or speed reduction measures should be considered with the relevant Highways Authority or council.

### 4.6 Other Considerations

#### 4.6.1 Current Rating of Shallow Cables

When cables are subject to shallow burial the normal assumptions for rating cable circuits may have to be modified to consider the following:

- The ground temperature cannot be assumed to be the same (at least in summertime) as for usual soil burial.
- The surface temperature cannot be assumed to be the same as the typical bulk soil temperature.
- De-rating caused by the steel duct air gap thermal resistance is different to that of a plastic duct.

For any Shallow Cables route, it must be demonstrated that the cable design will achieve the required ratings under the proposed laying conditions. The use of CRATER software or similar can be used to calculate the bespoke cable ratings. Refer to CP203 for more details.

#### 4.6.2 Structural Integrity on bridges

The addition of steel plates, or other materials will add considerable weight onto a bridge structure. All proposals must be fully approved by the asset owner to ensure there will be no effect on any waterproof membrane layers or overall structural integrity of their asset.

#### 4.6.3 Vibration of Shallow Cables on bridges

Shallow Cables and the ducts used may be subject to sustained vibrations on long bridges where regular heavy traffic occurs.

Consideration shall be given to use of expansion joints in steel sleeves to reduce any resonance between bridge and cables, and to use “snake laying” at either end of the Shallow Cable route to absorb vibrations.

Figure 1 - Example of HV Shallow Cable in bridge footway protected using Trief Kerb stone , fibre protection boards and steel duct over PVC duct

Jan 24

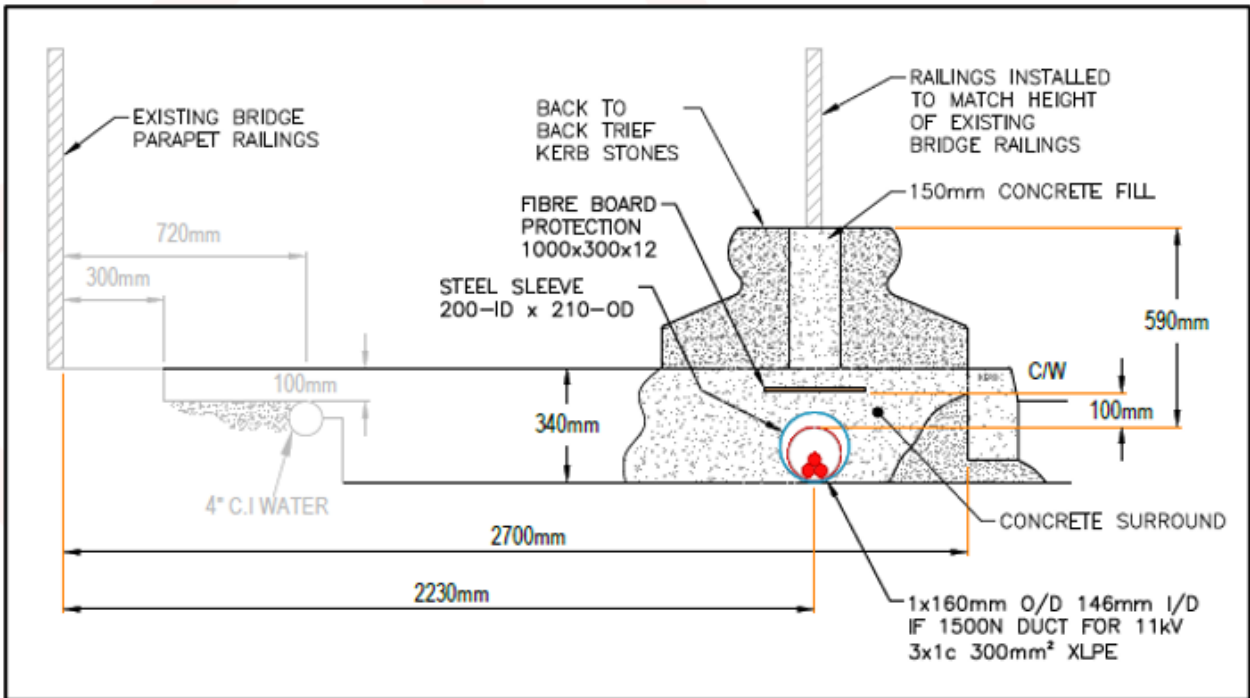
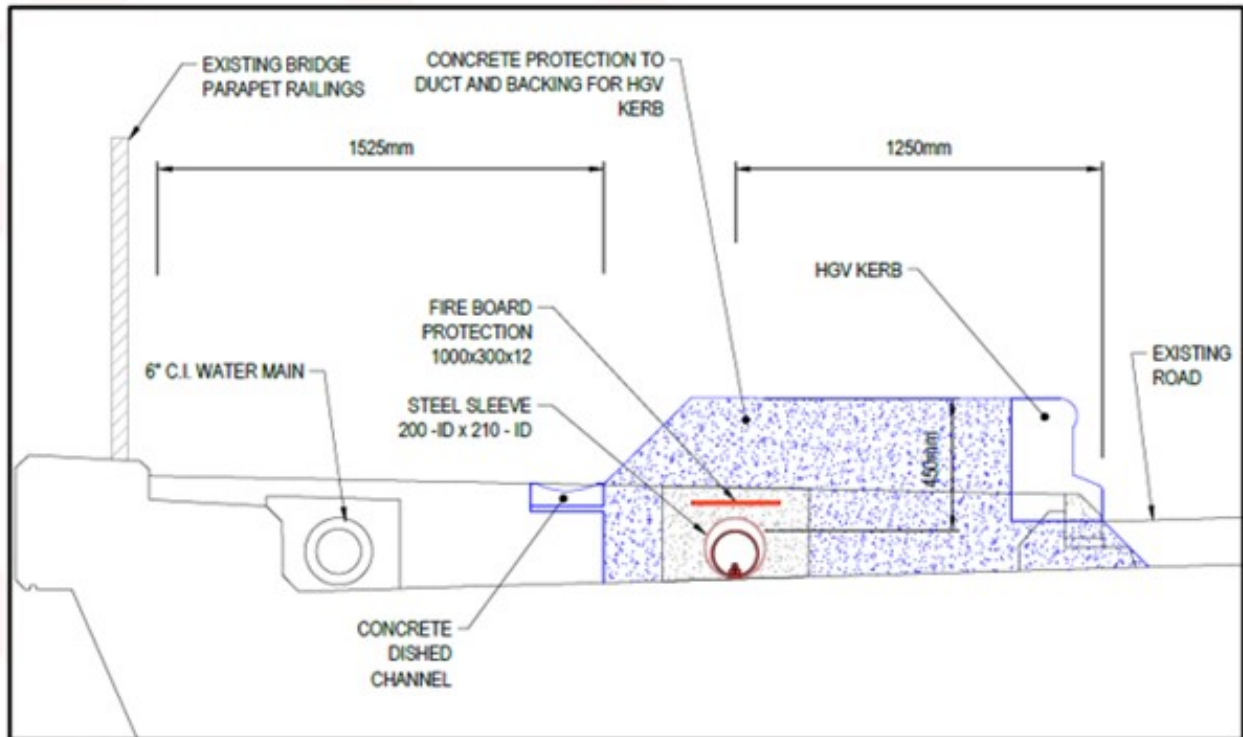

Figure 2 - Example of HV Shallow Cable in bridge footway protected using concrete built up kerb edge, fibreboard protection and steel duct over PVC duct

Jan 24





## 5 Example Risk Assessment Layout

Jan 24

FORSEEABLE RISKS IDENTIFIED	WHEN DOES THE HAZARD/RISK APPLY				ADDITIONAL MEASURES PROPOSED TO ELIMINATE OR REDUCE THE RISK	IS A RESIDUAL RISK STILL PRESENT
	(can be one or more of the following)					
Any Risk that has a potential to cause harm to those constructing, repairing / maintaining, demolishing, or using the structure / route	Construction	Maintenance	In Use	Demolition	What mitigation measures are to be taken by the designer to eliminate risk?  An explanation of the reduction and controls necessary and the significance of the residual risk.	The reasons why any remaining risks cannot be fully eliminated.  What is the likelihood and severity of any risks that cannot be fully eliminated
Damage to Cable during pull into Steel duct	X				Steel duct to be lined with PVC smooth walled duct.  Bellmouth to be used during pull to prevent damage from edges of steel duct	The risk is eliminated providing correct procedure followed.
Damage to Cable during any future excavation works from the use of mechanical cutting or compaction tools		X	X	X	Marked on GIS Records will give advance notification before any excavation works.  Surface mounted signage across length of route to provide local notification.  5mm thick Steel Plate laid at 50mm above Steel duct with warning tape to indicate cables laid below for mechanical protection against penetration of cover.  Surface level raised with elevated kerb edge to give minimum 300mm high depth of cover (at "worse case" position)	The likelihood of the risk is low, and the severity of the risk is reduced due to the mitigation measures used.
Damage to Cable from errant vehicle overrun or high-speed overturn		X	X	X	Elevated kerb located at roadside, with duct encased in concrete within existing hard standing. The additional concrete backing behind the kerb will increase the concrete cover over the duct to 300mm.  Speed restriction of 30mph on bridge with speed limit repeater signs placed immediately before entering to reduce risk of high-speed overturn.	Whilst cover to duct is less than desired, the mitigation measures significantly reduce the risk of damage to the duct because of vehicle overrun.

## 6 Documents Referenced

DOCUMENTS REFERENCED	
ESQCR	Electrical Safety, Quality and Continuity Regulations
ENA Engineering Recommendation C98	MV Cables Crossing Bridges - Physical Protection and Current Ratings
CP012	Electricity Geographical Information System (GIS)
CP203	Code of Practice for Underground Cable Ratings
ES356	Notices and Nameplates
ES400 E4	ENWL Specification for Installation Commissioning and Repairs of Solid HV and LV Cables
ES400 E5	ENWL Specification for Installation Commissioning and Repairs of 33kV and 132kV Cables